

SECTION **FAX**
FRONT AXLE

A
B
C

FAX

CONTENTS

PRECAUTION	2	FRONT DRIVE SHAFT BOOT	11	F
PRECAUTIONS	2	Exploded View	11	
Precaution for Supplemental Restraint System (SRS) "AIR BAG" and "SEAT BELT PRE-TENSIONER"	2	WHEEL SIDE	12	G
Precautions for Drive Shaft	2	WHEEL SIDE : Removal and Installation	12	
PREPARATION	3	TRANSAXLE SIDE	14	H
PREPARATION	3	TRANSAXLE SIDE : Removal and Installation	14	
Special Service Tool	3	FRONT DRIVE SHAFT	18	I
Commercial Service Tool	3	Exploded View (LH)	18	
SYMPTOM DIAGNOSIS	5	Removal and Installation (LH)	18	J
NOISE, VIBRATION, AND HARSHNESS (NVH) TROUBLESHOOTING	5	Exploded View (RH)	20	
NVH Troubleshooting Chart	5	Removal and Installation (RH)	20	K
PERIODIC MAINTENANCE	6	UNIT DISASSEMBLY AND ASSEMBLY ...	24	L
FRONT WHEEL HUB	6	FRONT DRIVE SHAFT	24	
On-vehicle Service	6	Exploded View (LH)	24	
Inspection	6	Disassembly and Assembly (LH)	24	
FRONT DRIVE SHAFT	7	Exploded View (RH)	29	
Inspection	7	Disassembly and Assembly (RH)	30	
REMOVAL AND INSTALLATION	8	SERVICE DATA AND SPECIFICATIONS (SDS)	37	M
FRONT WHEEL HUB	8	SERVICE DATA AND SPECIFICATIONS (SDS)	37	N
Exploded View	8	Wheel Bearing	37	
Removal and Installation	8	Drive Shaft	37	
		Dynamic Damper	37	
		Boot Bands	38	O

E
F
G
H
I
J
K
L
M
N
O
P

PRECAUTIONS

< PRECAUTION >

PRECAUTION

PRECAUTIONS

Precaution for Supplemental Restraint System (SRS) "AIR BAG" and "SEAT BELT PRE-TENSIONER"

INFOID:000000012226956

The Supplemental Restraint System such as "AIR BAG" and "SEAT BELT PRE-TENSIONER", used along with a front seat belt, helps to reduce the risk or severity of injury to the driver and front passenger for certain types of collision. Information necessary to service the system safely is included in the SR and SB section of this Service Manual.

WARNING:

- To avoid rendering the SRS inoperative, which could increase the risk of personal injury or death in the event of a collision which would result in air bag inflation, all maintenance must be performed by an authorized NISSAN/INFINITI dealer.
- Improper maintenance, including incorrect removal and installation of the SRS, can lead to personal injury caused by unintentional activation of the system. For removal of Spiral Cable and Air Bag Module, see the SR section.
- Do not use electrical test equipment on any circuit related to the SRS unless instructed to in this Service Manual. SRS wiring harnesses can be identified by yellow and/or orange harnesses or harness connectors.

PRECAUTIONS WHEN USING POWER TOOLS (AIR OR ELECTRIC) AND HAMMERS

WARNING:

- When working near the Airbag Diagnosis Sensor Unit or other Airbag System sensors with the Ignition ON or engine running, DO NOT use air or electric power tools or strike near the sensor(s) with a hammer. Heavy vibration could activate the sensor(s) and deploy the air bag(s), possibly causing serious injury.
- When using air or electric power tools or hammers, always switch the Ignition OFF, disconnect the battery and wait at least three minutes before performing any service.

Precautions for Drive Shaft

INFOID:000000011935305

Observe the following precautions when disassembling and assembling drive shaft.

- Joint sub-assembly does not disassemble because it is non-overhaul parts.
- Perform work in a location which is as dust-free as possible.
- Before disassembling and assembling, clean the outside of parts.
- Prevention of the entry of foreign objects must be taken into account during disassembly of the service location.
- Disassembled parts must be carefully reassembled in the correct order. If work is interrupted, a clean cover must be placed over parts.
- Paper shop cloths must be used. Fabric shop cloths must not be used because of the danger of lint adhering to parts.
- Disassembled parts (except for rubber parts) should be cleaned with kerosene which shall be removed by blowing with air or wiping with paper shop cloths.

PREPARATION

< PREPARATION >



PREPARATION

PREPARATION

Special Service Tool

INFOID:000000011935306

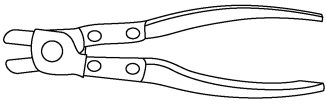
The actual shape of the tools may differ from those illustrated here.

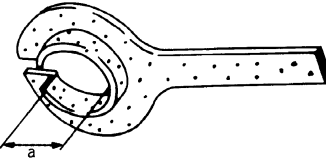
Tool number (TechMate No.) Tool name	Description
KV40107300 (J-51751) Boot band crimping tool  ALDIA0586ZZ	Installing boot band
KV40107500 (—) Drive shaft attachment  ZZA1230D	Removing drive shaft
KV38107900 (—) Protector  PDIA1183J	Installing drive shaft a: 32 mm (1.26 in) dia.

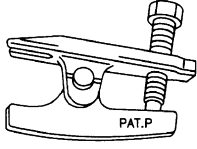
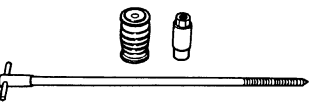

Commercial Service Tool

INFOID:000000011935307

Tool name	Description
Ball joint remover  PAT.P NT146	Removing wheel stud
Drive shaft puller  JPDIG0152ZZ	Removing drive shaft joint sub-assembly

PREPARATION

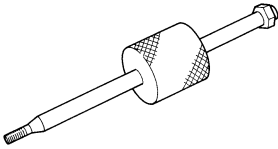
< PREPARATION >

Tool name	Description
Sliding hammer  ZZA0023D	Removing drive shaft
Power tool  PIIB1407E	Loosening nuts, screws and bolts

NOISE, VIBRATION, AND HARSHNESS (NVH) TROUBLESHOOTING

< SYMPTOM DIAGNOSIS >

SYMPTOM DIAGNOSIS

NOISE, VIBRATION, AND HARSHNESS (NVH) TROUBLESHOOTING

NVH Troubleshooting Chart

INFOID:0000000011935308

Use chart below to help you find the cause of the symptom. If necessary, repair or replace these parts.

Reference page		— FAX-24 , FAX-30 FAX-7 FAX-18 , FAX-20 — FAX-6 FSU-5 FAX-6 WT-62 WT-62 FAX-7 BR-6 ST-28												
Possible cause and SUSPECTED PARTS		Excessive joint angle	Joint sliding resistance	Imbalance	Improper installation, looseness	Parts interference	Wheel bearing damage	FRONT SUSPENSION	FRONT AXLE	TIRE	WHEEL	DRIVE SHAFT	BRAKES	STEERING
Symptom	DRIVE SHAFT	Noise	x	x			x	x	x	x	x		x	x
		Shake	x		x			x	x	x	x		x	x
	FRONT AXLE	Noise				x	x	x	x	x	x	x	x	x
		Shake				x	x	x	x	x	x	x	x	x
		Vibration				x	x	x	x	x		x		x
		Shimmy				x	x		x		x		x	x
		Shudder				x			x		x	x		x
Poor quality ride or handling				x	x		x		x	x				

x: Applicable

A
B
C
D
E
F
G
H
I
J
K
L
M
N
O
P

FAX

FRONT WHEEL HUB

< PERIODIC MAINTENANCE >

PERIODIC MAINTENANCE

FRONT WHEEL HUB

On-vehicle Service

INFOID:000000012216002

Check axle and suspension parts for excessive play, wear or damage.

- Move the wheel as shown to check for excessive play.

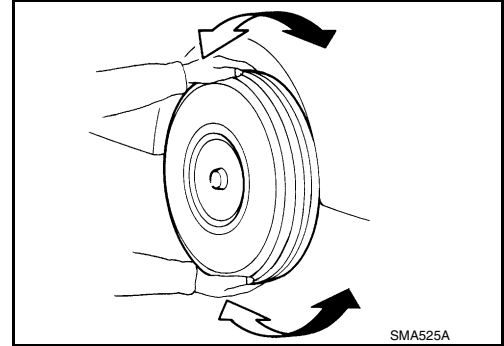

Inspection

INFOID:000000011935309

- Move wheel hub and bearing in an axial direction by hand to verify if looseness of wheel hub and bearing exists. If any looseness exists, replace the wheel hub and bearing.

Axial end play : Refer to [FAX-37, "Wheel Bearing"](#).

- Rotate wheel hub to verify if unusual noises or irregular conditions exist. If any irregular conditions exist, replace the wheel hub and bearing.

FRONT DRIVE SHAFT

< PERIODIC MAINTENANCE >

FRONT DRIVE SHAFT

Inspection

INFOID:000000011935310

- Check drive shaft mounting point and joint for looseness and other damage.
- Check boot for cracks and other damage.

CAUTION:

Replace entire drive shaft when noise or vibration occurs from drive shaft.

A

B

C

FAX

E

F

G

H

I

J

K

L

M

N

O

P

FRONT WHEEL HUB

< REMOVAL AND INSTALLATION >

REMOVAL AND INSTALLATION

FRONT WHEEL HUB

Exploded View

INFOID:000000012203374

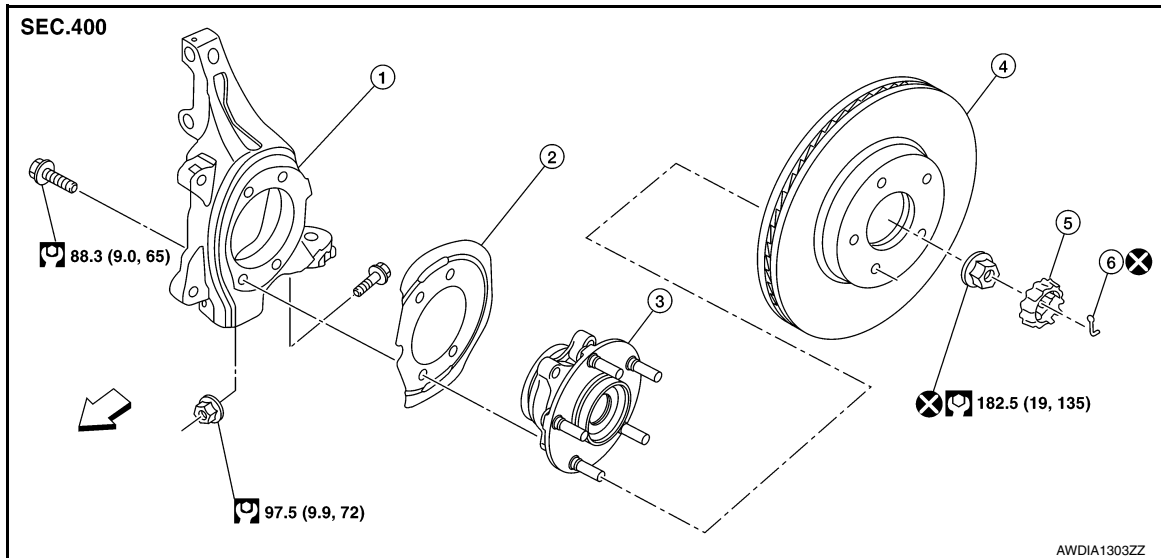

- | | | |
|---------------------|-----------------|--------------------------|
| 1. Steering knuckle | 2. Splash guard | 3. Wheel hub and bearing |
| 4. Rotor | 5. Nut retainer | 6. Cotter pin |
| ⇐ Front | | |

Removal and Installation

INFOID:000000011935311

REMOVAL

1. Remove disc brake rotor. Refer to [BR-41, "DISC BRAKE ROTOR : Removal and Installation"](#).
2. Remove front wheel sensor bolt (A) and front wheel sensor from steering knuckle. Refer to [FAX-8, "Exploded View"](#).

CAUTION:

- Failure to separate front wheel sensor from steering knuckle may result in damage to front wheel sensor.
- Pull out front wheel sensor being careful to turn it as little as possible. Do not pull on wheel sensor harness.

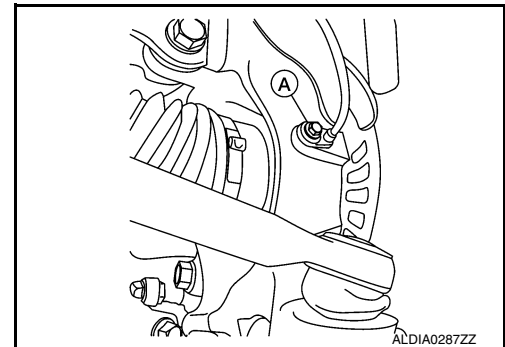

3. Remove cotter pin.
4. Remove nut retainer.
5. Loosen wheel hub lock nut from drive shaft using a power tool.

FRONT WHEEL HUB

< REMOVAL AND INSTALLATION >

6. Using a piece of wood and a suitable tool, tap on the wheel hub lock nut to disengage drive shaft from wheel hub and bearing.

CAUTION:

- Do not place drive shaft joint to an extreme angle. Also be careful not to overextend slide joint.
- Do not allow drive shaft to hang down without support.

NOTE:

Use a suitable puller if drive shaft cannot be separated from wheel hub and bearing.

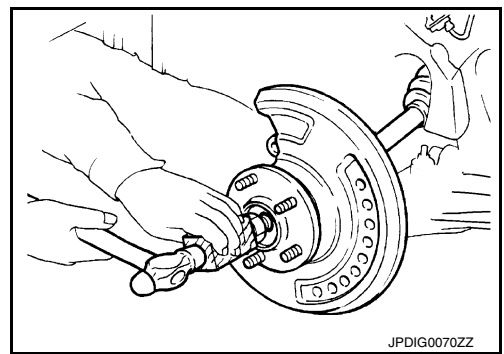

7. Remove wheel hub lock nut.
8. Remove wheel hub and bearing bolts using a power tool.
9. Remove splash guard and wheel hub and bearing from steering knuckle.
10. If necessary, remove wheel studs (1) using a suitable tool (A).

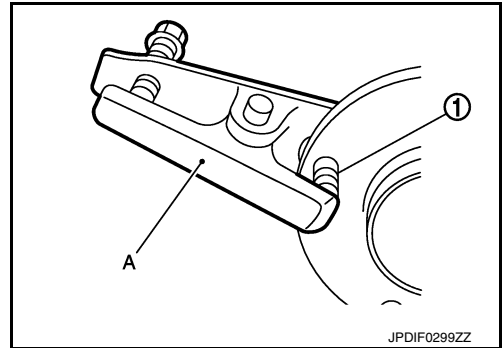

INSPECTION AFTER REMOVAL

Check components for deformation, cracks, and other damage. Replace if necessary.

INSTALLATION

Installation is in the reverse order of removal.

CAUTION:

- Do not reuse wheel stud.
- Do not reuse cotter pin.
- Place a washer (A) as shown to install wheel studs (1) by using tightening force of nut (B).

CAUTION:

Check that there is no clearance between wheel stud and wheel hub and bearing.

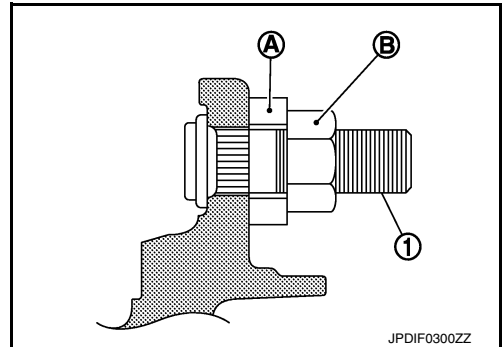

- Clean mating surfaces of wheel hub lock nut and wheel hub and bearing.

CAUTION:

Do not apply lubricating oil to these mating surfaces.

- Hold wheel hub and bearing using a suitable tool. Tighten wheel hub lock nut.

CAUTION:

- Since drive shaft is assembled by press-fitting, use a torque wrench to tighten wheel hub lock nut. Do not use a power tool.
- Too much torque causes axle noise. Too little torque causes wheel bearing looseness.

FRONT WHEEL HUB

< REMOVAL AND INSTALLATION >

- When installing cotter pin (1) and nut retainer (2), securely bend cotter pin to prevent rattles.

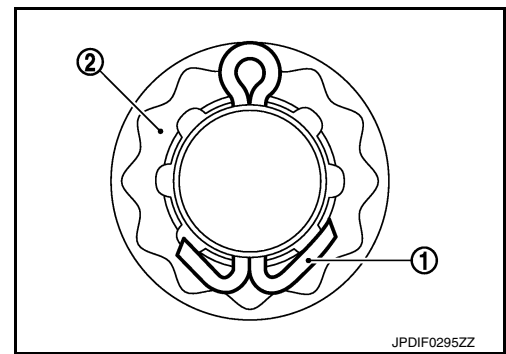

CAUTION:

Do not reuse the cotter pin or the wheel hub lock nut.

- When installing wheel hub and bearing assembly to steering knuckle, align cutout in sensor rotor cover with wheel sensor mounting hole in steering knuckle.
- Align the marks (A) made on the disc brake rotor and front wheel hub and bearing during disassembly.

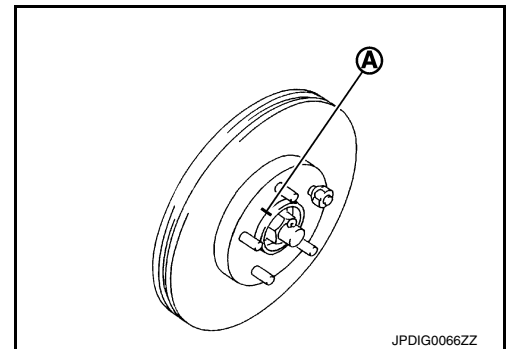

FRONT DRIVE SHAFT BOOT

< REMOVAL AND INSTALLATION >

FRONT DRIVE SHAFT BOOT

Exploded View

INFOID:000000012219125

LH

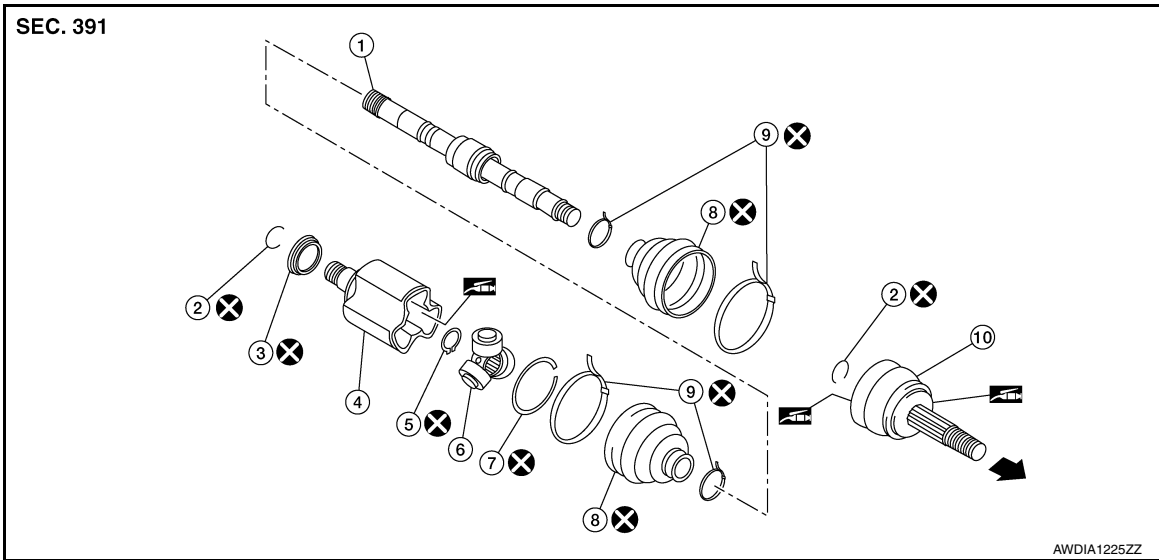

- | | | |
|------------------------|------------------|-------------------------------------|
| 1. Shaft with damper | 2. Circular clip | 3. Dust shield |
| 4. Housing | 5. Snap ring | 6. Spider assembly |
| 7. Stopper ring | 8. Boot | 9. Boot band |
| 10. Joint sub-assembly | ← Wheel side | 🛢️ Fill with Genuine NISSAN Grease. |

RH

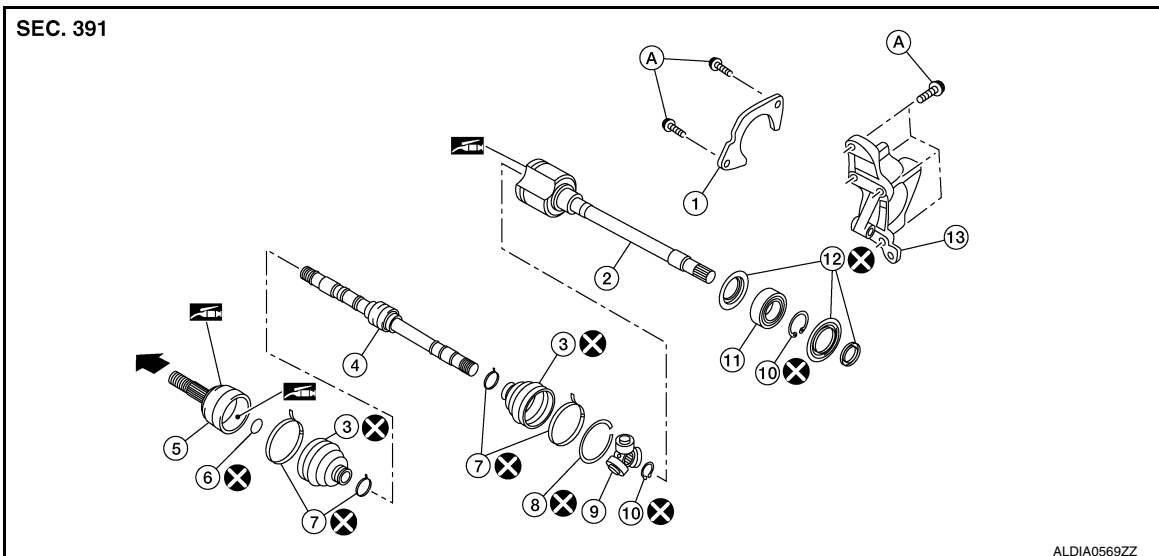

- | | | |
|-----------------------------|---|--------------------|
| 1. Support bearing retainer | 2. Housing | 3. Boot |
| 4. Shaft with damper | 5. Joint sub-assembly | 6. Circular clip |
| 7. Boot band | 8. Stopper ring | 9. Spider assembly |
| 10. Snap ring | 11. Support bearing | 12. Dust shield |
| 13. Support bearing bracket | A. Refer to FRONT DRIVE SHAFT INSTALLATION. | ← Wheel side |

🛢️ Fill with Genuine NISSAN Grease.

A
B
C
FAX
E
F
G
H
I
J
K
L
M
N
O
P

FRONT DRIVE SHAFT BOOT

< REMOVAL AND INSTALLATION >

WHEEL SIDE

WHEEL SIDE : Removal and Installation

INFOID:000000012219126

REMOVAL

1. Remove front drive shaft. Refer to [FAX-18. "Removal and Installation \(LH\)"](#) (LH) or [FAX-20. "Removal and Installation \(RH\)"](#) (RH).

2. Secure the front drive shaft in a vise.

CAUTION:

When securing shaft in a vise, always use copper or aluminum plates between vise and shaft.

3. Remove boot bands and slide the boot back.

4. Screw a suitable tool (A) 30 mm (1.18 in) or more into threaded part of joint sub-assembly. Pull joint sub-assembly out of shaft.

CAUTION:

- Align suitable tool (B) and drive shaft then remove joint sub-assembly by pulling directly.
- If joint sub-assembly cannot be removed after five or more unsuccessful attempts, replace the entire drive shaft.

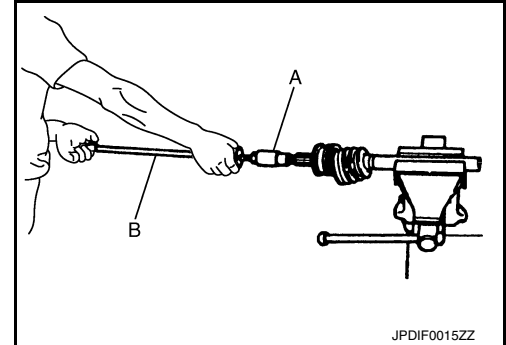

5. Remove boot from shaft.

6. Remove circular clip from shaft.

7. While rotating ball cage, clean the old grease off the joint sub-assembly.

INSPECTION AFTER REMOVAL

- Move joint up/down, left/right, and in axial directions. Check for motion that is not smooth and for significant looseness.
- Check boot for cracks, damage, and leakage of grease.

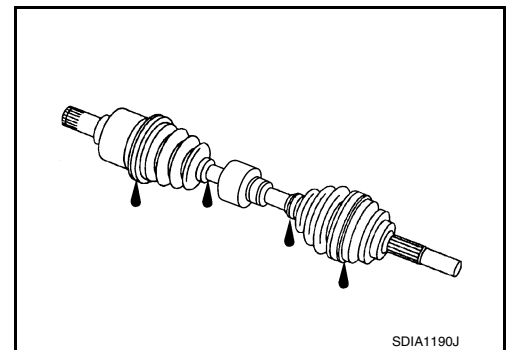

INSTALLATION

1. Insert Genuine NISSAN Grease into joint sub-assembly (1) seration hole until grease begins to ooze from ball groove and seration hole.

CAUTION:

After inserting grease, use a paper shop cloth to wipe off old grease that has oozed out.

NOTE:

Always check with the Parts Department for the latest parts information.

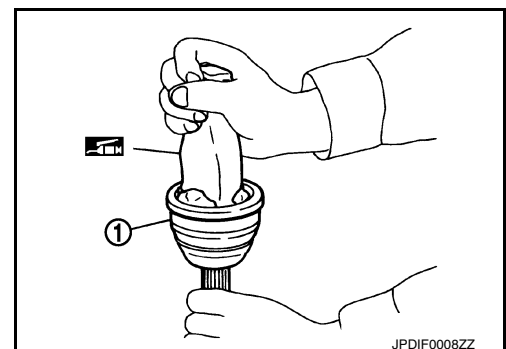

FRONT DRIVE SHAFT BOOT

< REMOVAL AND INSTALLATION >

2. Install new boot and new small boot band on shaft.

CAUTION:

- Do not reuse the boot and boot bands.
- Cover drive shaft serration with protective tape (A) to prevent damage to boot during installation.

3. Remove protective tape wound around serrated part of shaft.

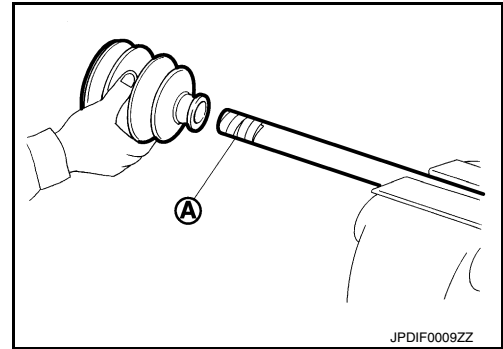

4. Attach new circular clip to shaft. Circular clip must fit securely into shaft groove. Attach nut to joint sub-assembly. Use a suitable tool to press-fit.

CAUTION:

Do not reuse circular clip.

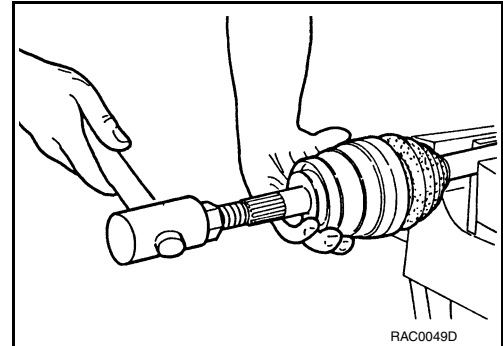

5. Insert specified amount of new Genuine NISSAN Grease listed below into housing from large end of boot.

Grease quantity : Refer to [FAX-37, "Drive Shaft"](#).

NOTE:

Always check with the Parts Department for the latest parts information.

6. Install boot securely into grooves (indicated by * marks) as shown.

CAUTION:

If there is grease on boot mounting surfaces (indicated by * marks) of shaft and housing, boot may come off. Remove all grease from surfaces.

7. Make sure boot installation length (L) is the specified length indicated below. Insert a suitable tool into the large end of boot. Bleed air from boot to prevent boot deformation.

Boot installation length (L)

: Refer to [FAX-37, "Drive Shaft"](#).

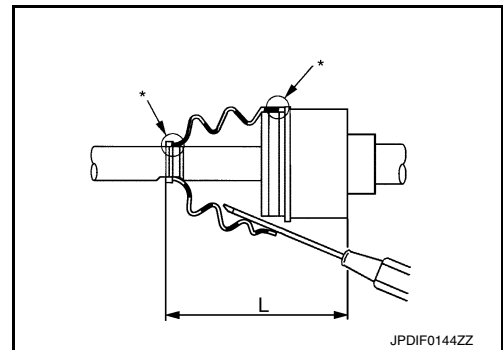

CAUTION:

- Boot may break if boot installation length is less than standard value.
- Be careful that suitable tool does not contact inside surface of boot.

8. Install new large and small boot bands securely using Tool.

Tool number : KV40107300 (J-51751)

CAUTION:

Do not reuse boot bands.

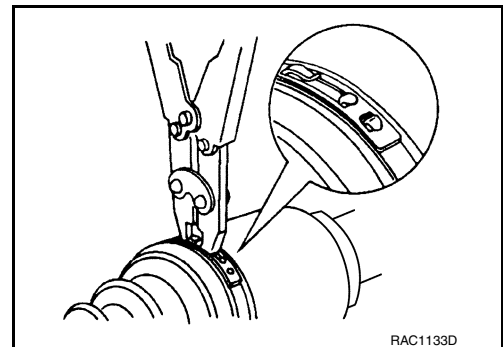

NOTE:

A
B
C
FAX
E
F
G
H
I
J
K
L
M
N
O
P

FRONT DRIVE SHAFT BOOT

< REMOVAL AND INSTALLATION >

Secure boot band so that dimension (M) meets specification as shown.

Dimension (M) : Refer to [FAX-38, "Boot Bands"](#).

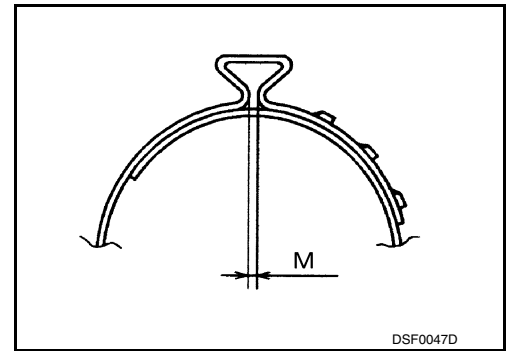

9. Attempt to rotate boot to check whether or not boot bands are securing it. If boot is not secure, remove boot bands, reposition boot, and install new boot bands.

CAUTION:

Do not reuse boot bands.

10. Install front drive shaft. Refer to [FAX-18, "Removal and Installation \(LH\)"](#) (LH) or [FAX-20, "Removal and Installation \(RH\)"](#) (RH).

INSPECTION AND ADJUSTMENT AFTER INSTALLATION

1. Check wheel alignment. Refer to [WT-63, "Inspection"](#).
2. Adjust neutral position of the steering angle sensor. Refer to [BRC-64, "Description"](#).

TRANSAXLE SIDE

TRANSAXLE SIDE : Removal and Installation

INFOID:0000000012219127

REMOVAL

1. Remove front drive shaft. Refer to [FAX-18, "Removal and Installation \(LH\)"](#) (LH) or [FAX-20, "Removal and Installation \(RH\)"](#) (RH).
2. Secure front drive shaft in a vise.
CAUTION:
When securing shaft in a vise, always use copper or aluminum plates between vise and shaft.
3. Remove boot bands and slide boot back.
4. Put matching marks on housing and shaft before separating housing.
CAUTION:
Use paint or an equivalent for matching marks. Do not scratch surfaces.
5. Remove stopper ring using a suitable tool.
6. Pull out housing.

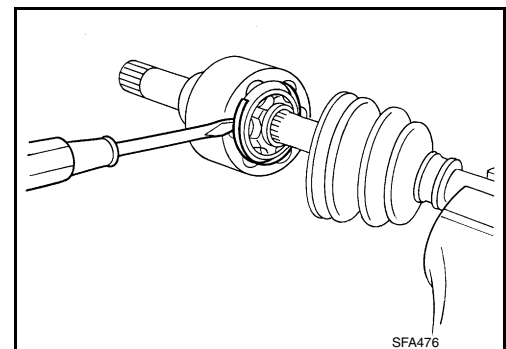

FRONT DRIVE SHAFT BOOT

< REMOVAL AND INSTALLATION >

- Put matching marks (A) on spider assembly and shaft.

CAUTION:

Use paint or an equivalent for matching marks. Do not scratch surfaces.

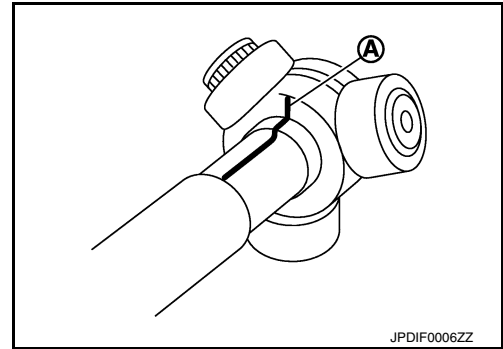

- Remove snap ring (1) using a suitable tool.
- Remove spider assembly from shaft.

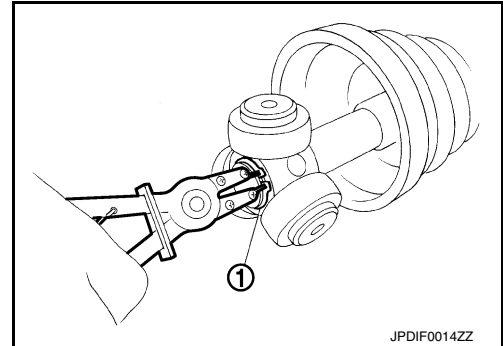

- Remove boot from shaft.
- Remove circular clip from housing.
- Remove dust shield from housing.
- Clean old grease off slide joint housing.

INSPECTION AFTER REMOVAL

Shaft

Check shaft for cracks or damage. Replace entire drive shaft if necessary.

Housing and Spider Assembly

Check housing and spider assembly for scratches or wear. Replace entire drive shaft if necessary.

Boot

Check boot for cracks, damage, and leakage of grease. Replace boot if necessary.

INSTALLATION

- Install new boot and new small boot band on shaft.

CAUTION:

- Do not reuse boot and boot bands.
- Cover drive shaft serration with protective tape (A) to prevent damage to boot during installation.

- Remove protective tape wound around serrated part of shaft.

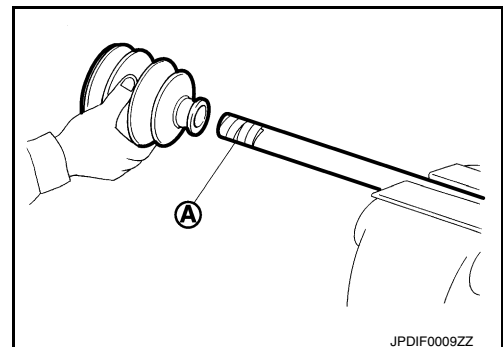

FRONT DRIVE SHAFT BOOT

< REMOVAL AND INSTALLATION >

- Align matching mark (A) on spider assembly (1) with matching mark on shaft (2). Install spider assembly to shaft with chamfer (B) facing shaft.

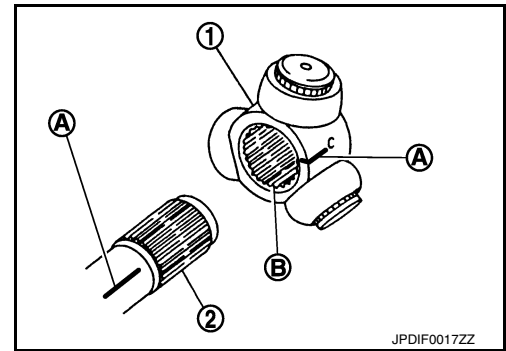

- Secure spider assembly onto shaft with snap ring (1) using a suitable tool.

CAUTION:

Do not reuse snap ring.

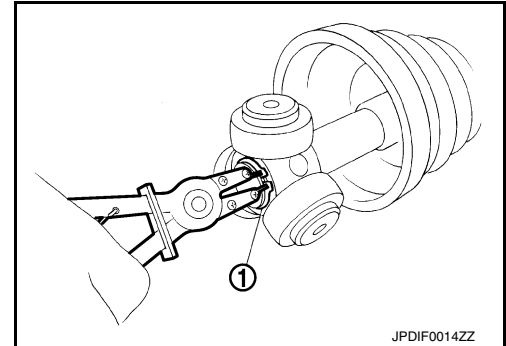

- Assemble housing onto spider assembly making sure to align matching marks made during disassembly, and fill with specified amount of new Genuine NISSAN Grease.

Grease quantity : Refer to [FAX-37, "Drive Shaft"](#).

NOTE:

Always check with the Parts Department for the latest parts information.

- Install new stopper ring to housing.

CAUTION:

Do not reuse stopper ring.

- After installation, pull shaft to check engagement between housing and stopper ring.
- Install boot securely into grooves (indicated by * marks) as shown.

CAUTION:

If there is grease on boot mounting surfaces (indicated by * marks) on shaft or housing, boot may come off. Clean all grease from surfaces.

- Make sure boot installation length (L) is length specified below. Insert a suitable tool into large end of boot. Bleed air from boot to prevent boot deformation.

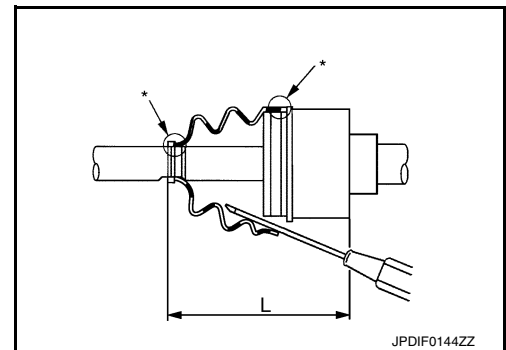

Boot installation length (L)

: Refer to [FAX-37, "Drive Shaft"](#).

CAUTION:

- Boot may break if boot installation length is less than standard value.
- Be careful that suitable tool does not contact inside surface of boot.

FRONT DRIVE SHAFT BOOT

< REMOVAL AND INSTALLATION >

10. Install new large and small boot bands securely using Tool.

Tool number : KV40107300 (J-51751)

CAUTION:

Do not reuse boot bands.

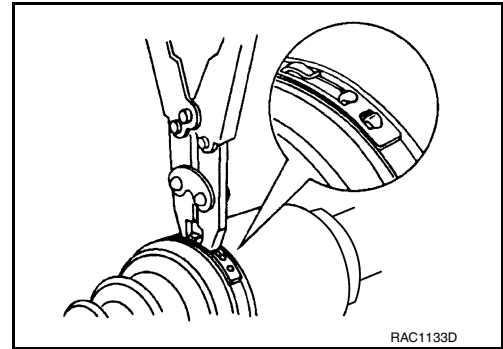

NOTE:

Secure boot band so that dimension (M) meets specification as shown.

Dimension (M) : Refer to [FAX-38. "Boot Bands"](#).

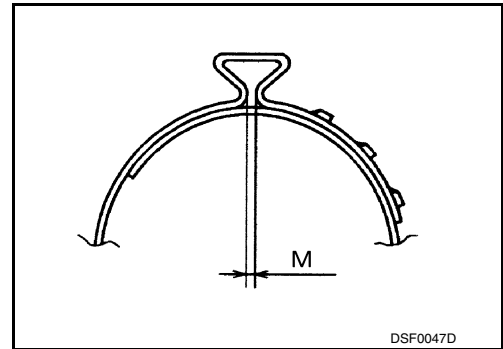

11. Install new dust shield to housing.

CAUTION:

Do not reuse dust shield.

12. Install new circular clip to housing.

CAUTION:

Do not reuse circular clip.

13. After installing housing and shaft, make sure boot position is correct. If boot position is not correct, remove old boot bands, then reposition boot and secure with new boot bands.

CAUTION:

Do not reuse boot bands.

14. Install drive shaft. Refer to [FAX-18. "Removal and Installation \(LH\)"](#) (LH) or [FAX-20. "Removal and Installation \(RH\)"](#) (RH).

A

B

C

FAX

E

F

G

H

I

J

K

L

M

N

O

P

FRONT DRIVE SHAFT

< REMOVAL AND INSTALLATION >

FRONT DRIVE SHAFT

Exploded View (LH)

INFOID:000000012203375

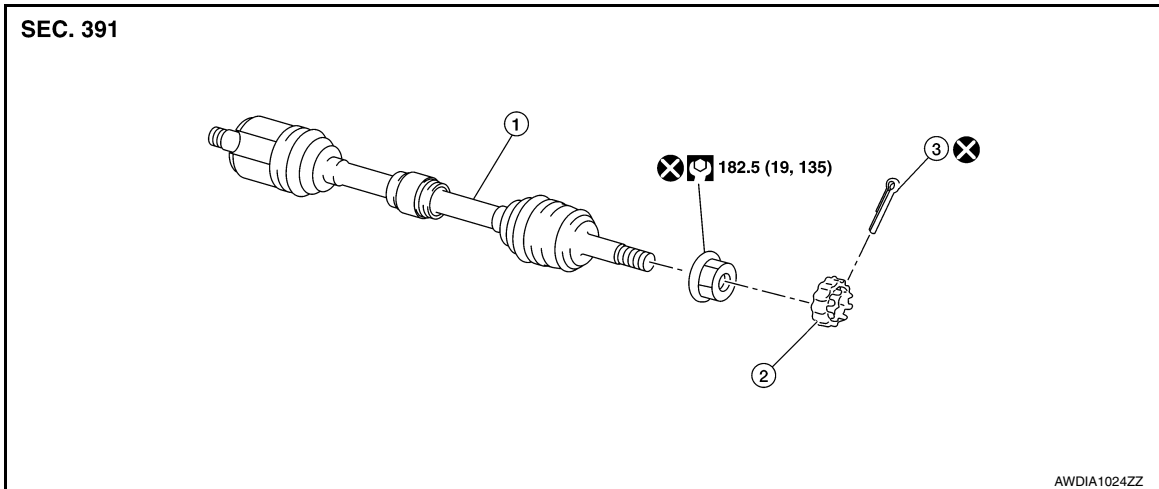

1. Front drive shaft

2. Nut retainer

3. Cotter pin

Removal and Installation (LH)

INFOID:000000011935312

REMOVAL

1. Remove disc brake rotor. Refer to [BR-41, "DISC BRAKE ROTOR : Removal and Installation"](#).
2. Remove front wheel sensor bolt (A) and front wheel sensor from steering knuckle. Refer to [BRC-167, "FRONT SENSOR ROTOR : Removal and Installation - Front Sensor Rotor"](#).

CAUTION:

- Failure to separate front wheel sensor from steering knuckle may result in damage to front wheel sensor.
- Pull out front wheel sensor being careful to turn it as little as possible. Do not pull on wheel sensor harness.

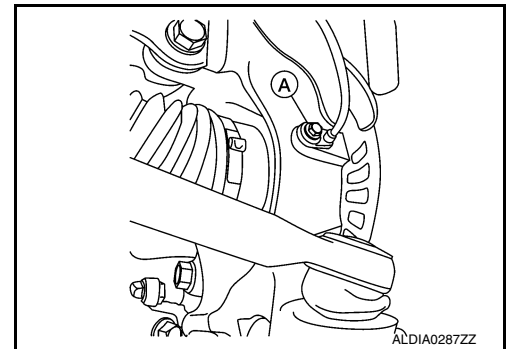

3. Remove brake hose retaining clip and brake hose from strut.
4. Remove cotter pin from drive shaft.
5. Remove nut retainer from drive shaft.
6. Loosen wheel hub lock nut from drive shaft using a power tool.
7. Remove front strut to steering knuckle bolts and nuts, then separate front strut from steering knuckle. Refer to [FSU-10, "Removal and Installation"](#).
8. Using a piece of wood and a suitable tool, tap on the wheel hub lock nut to disengage drive shaft from wheel hub and bearing.

CAUTION:

- Do not place drive shaft joint to an extreme angle. Also be careful not to overextend slide joint.
- Do not allow drive shaft to hang down without support.

NOTE:

Use a suitable puller if drive shaft cannot be separated from wheel hub and bearing.

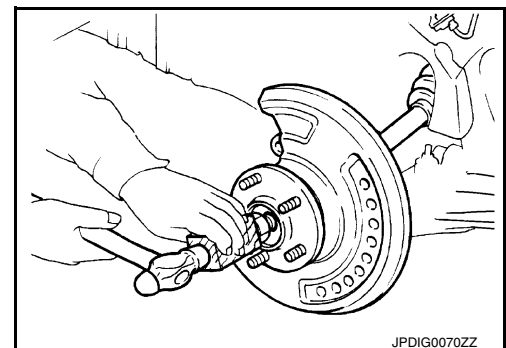

FRONT DRIVE SHAFT

< REMOVAL AND INSTALLATION >

9. Set Tool (A) and a suitable tool (B) between the drive shaft (slide joint side) and the transaxle as shown. Remove the drive shaft.

Tool number : KV40107500 (—)

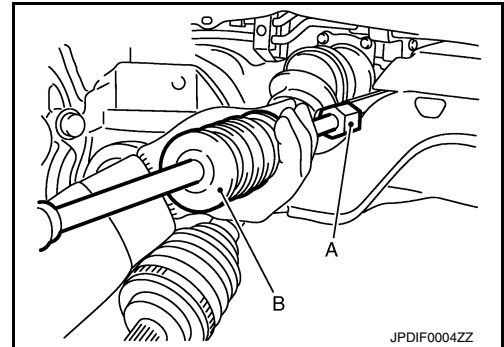

10. Remove the differential oil seal. Refer to [TM-204, "Removal and Installation"](#).

INSPECTION AFTER REMOVAL

- Move joint up/down, left/right, and in axial direction. Check for any rough movement or significant looseness.
- Check boot for cracks or other damage, and for grease leaks.
- If damaged, disassemble drive shaft to verify damage and repair or replace as necessary.

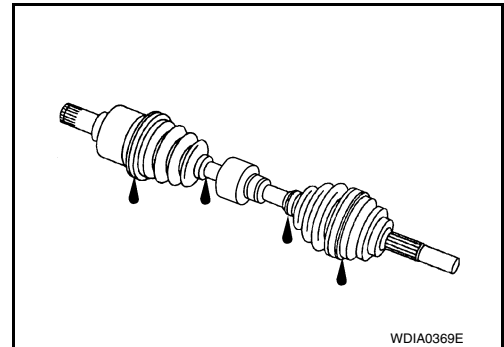

INSTALLATION

1. Install new differential side oil seal. Refer to [TM-204, "Removal and Installation"](#).

CAUTION:

Do not reuse differential side oil seal.

2. Install new circular clip on drive shaft in circular clip groove on transaxle side. Refer to [FAX-18, "Exploded View \(LH\)"](#).

CAUTION:

- **Do not reuse circular clip.**
- **Make sure new circular clip on drive shaft is securely fastened.**

3. In order to prevent damage to differential side oil seal, place Tool (A) onto oil seal before inserting drive shaft as shown. Slide drive shaft into slide joint and tap with a suitable tool to install securely.

Tool number : KV38107900 (—)

NOTE:

After its insertion, try to pull flange out of slide joint by hand. If it pulls out, circular clip is not properly meshed with transaxle side gear.

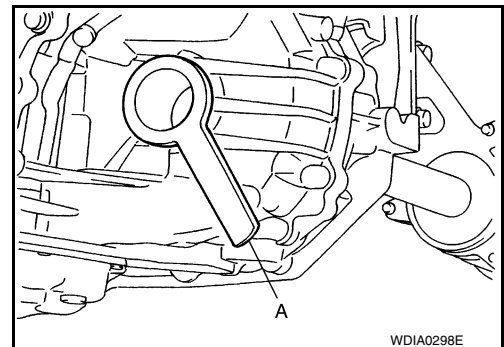

4. Clean mating surfaces of wheel hub lock nut and wheel hub and bearing.

CAUTION:

Do not apply lubricating oil to these mating surfaces.

5. Tighten wheel hub lock nut to specification. Refer to [FAX-18, "Exploded View \(LH\)"](#).

CAUTION:

- **Since drive shaft is assembled by press-fitting, use a torque wrench to tighten wheel hub lock nut. Do not use a power tool.**
- **Too much torque causes axle noise. Too little torque causes wheel bearing looseness.**

FRONT DRIVE SHAFT

< REMOVAL AND INSTALLATION >

- When installing cotter pin (1) and nut retainer (2), securely bend cotter pin to prevent rattles.

CAUTION:
Do not reuse cotter pin.

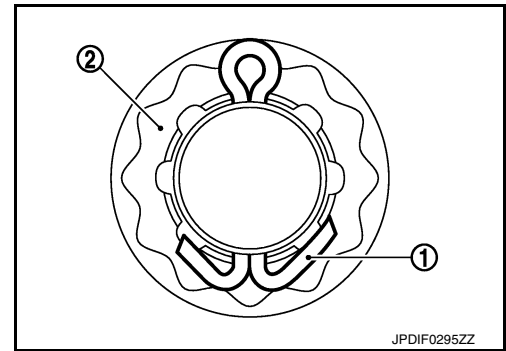

JPDIF0295ZZ

- Remainder of installation is in reverse order of removal.

INSPECTION AND ADJUSTMENT AFTER INSTALLATION

- Check CVT fluid level and leakage. Refer to [TM-82, "Adjustment"](#).
- Check wheel alignment. Refer to [FSU-7, "Inspection"](#).
- Adjust the neutral position of the steering angle sensor. Refer to [BRC-248, "Description"](#).

Exploded View (RH)

INFOID:000000012203376

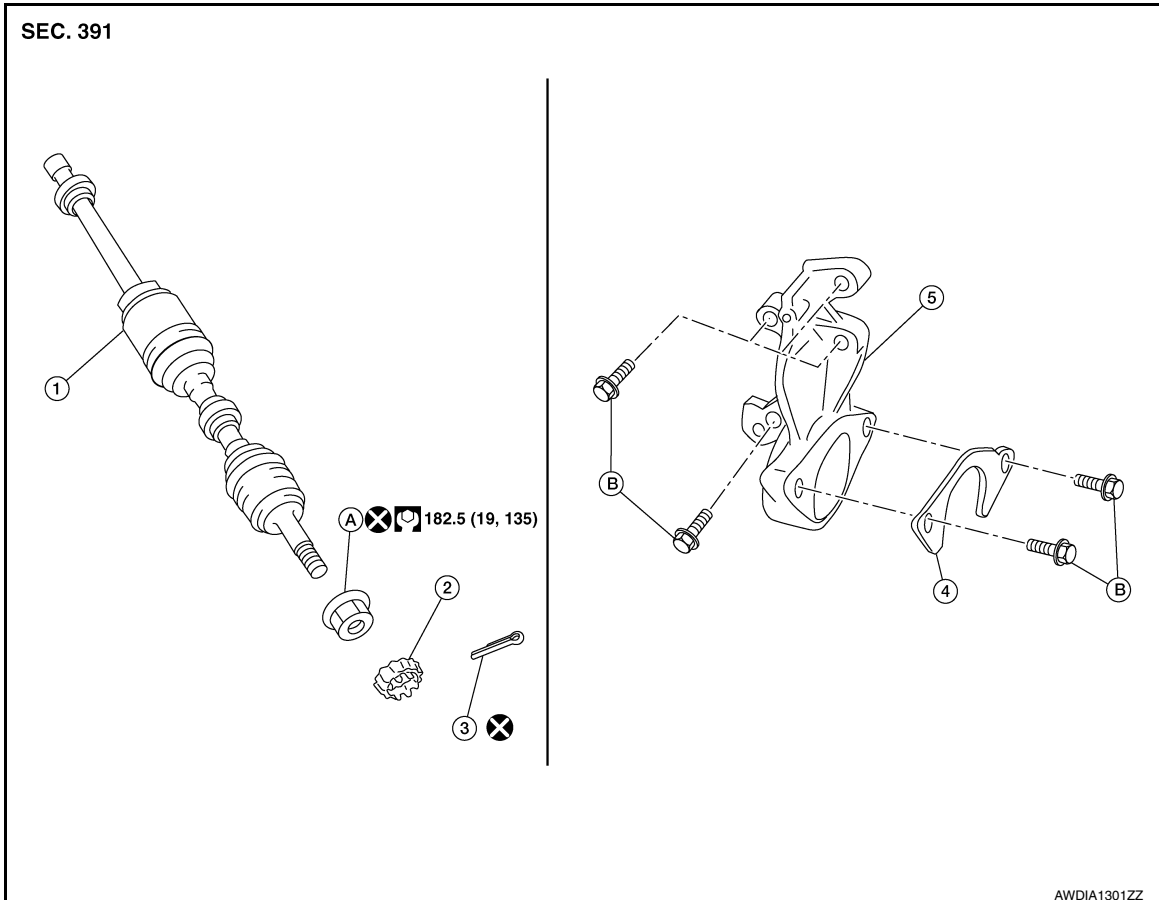

- | | | |
|---------------------------|----------------------------|-----------------------|
| 1. Front drive shaft | 2. Nut retainer | 3. Cotter pin |
| 4. Bearing retainer | 5. Support bearing bracket | A. Wheel hub lock nut |
| B. Refer to INSTALLATION. | | |

Removal and Installation (RH)

INFOID:000000011935313

REMOVAL

- Remove disc brake rotor. Refer to [BR-41, "DISC BRAKE ROTOR : Removal and Installation"](#).

FRONT DRIVE SHAFT

< REMOVAL AND INSTALLATION >

- Remove front wheel sensor bolt (A) and front wheel sensor from steering knuckle. Refer to [BRC-362, "FRONT WHEEL SENSOR : Exploded View"](#).

CAUTION:

- Failure to separate front wheel sensor from steering knuckle may result in damage to front wheel sensor.
- Pull out front wheel sensor being careful to turn it as little as possible. Do not pull on front wheel sensor harness.

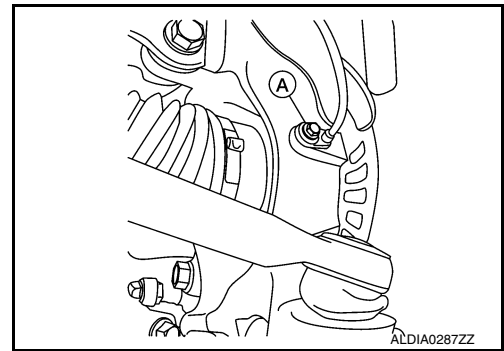

- Remove brake hose retaining clip and brake hose from strut.
- Remove cotter pin from drive shaft.
- Remove nut retainer from drive shaft.
- Loosen wheel hub lock nut from drive shaft using a power tool.
- Remove front strut to steering knuckle bolts and nuts, then separate front strut from the steering knuckle. Refer to [FSU-10, "Removal and Installation"](#).

- Using a piece of wood and a suitable tool, tap on the wheel hub lock nut to disengage drive shaft from wheel hub and bearing.

CAUTION:

- Do not place drive shaft joint to an extreme angle. Also be careful not to overextend slide joint.
- Do not allow drive shaft to hang down without support.

NOTE:

Use a suitable puller if drive shaft cannot be separated from wheel hub and bearing assembly.

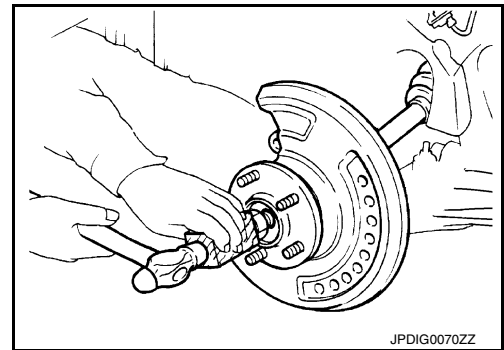

- Remove the bearing retainer to support bearing bracket bolts.

- Remove RH drive shaft from transaxle.

- Use Tool (A) and suitable tool (B) while inserting tip of tool between housing and transaxle.

CAUTION:

Do not place drive shaft joint at an extreme angle when removing drive shaft. Do not overextend slide joint.

Tool number (A) : KV40107500 (—)

- Remove differential side oil seal. Refer to [TM-204, "Removal and Installation"](#).

- If necessary, remove bolts and support bearing bracket.

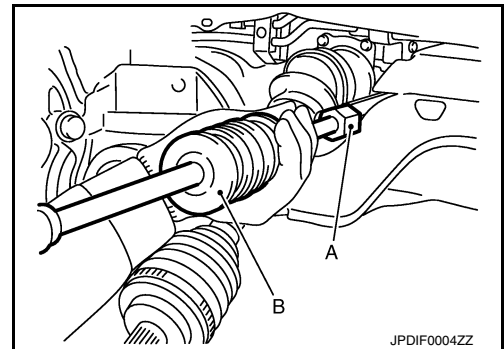

INSPECTION AFTER REMOVAL

- Move joint up/down, left/right, and in axial direction. Check for any rough movement or significant looseness.
- Check boot for cracks or other damage and for grease leaks.
- If damaged, disassemble drive shaft to verify damage, and repair or replace as necessary.

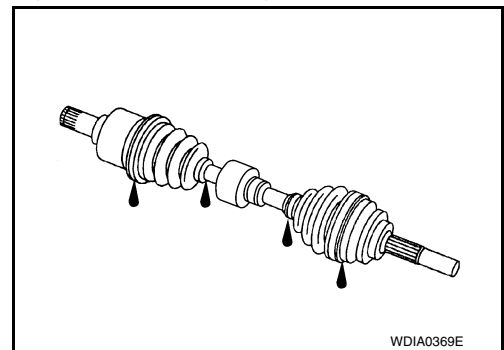

INSTALLATION

FRONT DRIVE SHAFT

< REMOVAL AND INSTALLATION >

1. Install support bearing bracket.
 - Tighten support bearing bracket bolts in numerical order as shown.
 - Refer to following for installation positions of bolts.

M10 bolt **No. 1 - 4:** **48.0 N·m (4.9 kg-m,**
35 ft-lb)

⇐ : Front

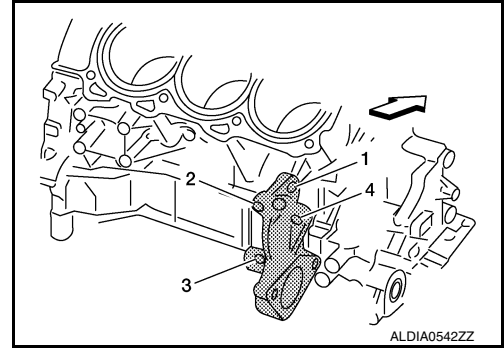

2. Install a new differential side oil seal. Refer to [TM-204, "Removal and Installation"](#).

CAUTION:

Do not reuse differential side oil seal.

3. Install new circular clip on drive shaft in circular clip groove on transaxle side. Refer to [FAX-20, "Exploded View \(RH\)"](#).

CAUTION:

- **Do not reuse circular clip.**
- **Make sure new circular clip on drive shaft is securely fastened.**

4. In order to prevent damage to differential side oil seal, place Tool (A) onto oil seal before inserting drive shaft as shown. Slide drive shaft into slide joint and tap with a hammer to install securely.

Tool number : **KV38107900 (—)**

NOTE:

After its insertion, try to pull flange out of slide joint by hand. If it pulls out, circular clip is not properly meshed with transaxle side gear.

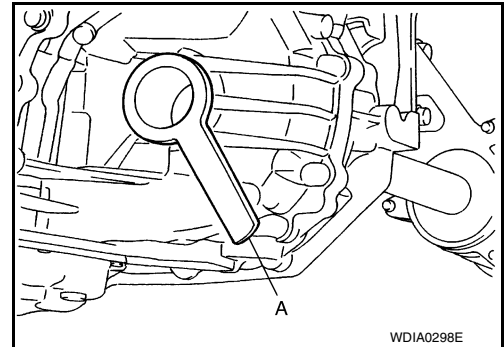

5. Install bearing retainer.
 - Tighten bearing retainer bolts in numerical order shown.

M8 bolt **No. 1 and No. 2:** **25.0 N·m (2.6 kg-m,**
18 ft-lb)

⇐ : Front

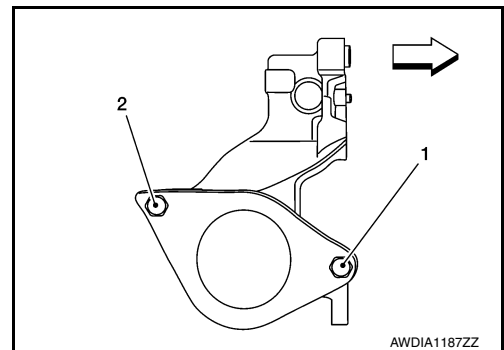

6. Clean mating surfaces of wheel hub lock nut and wheel hub and bearing.

CAUTION:

Do not apply lubricating oil to these surfaces.

7. Tighten wheel hub lock nut to specification. Refer to [FAX-20, "Exploded View \(RH\)"](#).

CAUTION:

- **Since drive shaft is assembled by press-fitting, use a torque wrench to tighten wheel hub lock nut. Do not use a power tool.**
- **Too much torque causes axle noise. Too little torque causes wheel bearing looseness.**

FRONT DRIVE SHAFT

< REMOVAL AND INSTALLATION >

- When installing cotter pin (1) and nut retainer (2), securely bend cotter pin to prevent rattles.

CAUTION:

Do not reuse cotter pin.

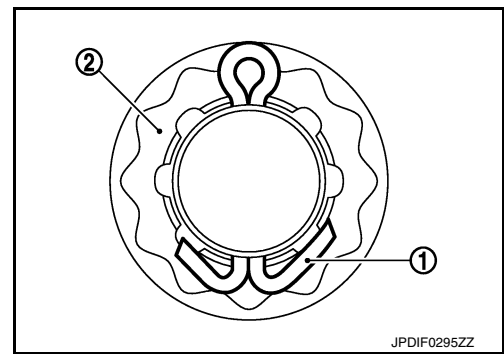

Installation of remaining components is in reverse order of removal.

INSPECTION AND ADJUSTMENT AFTER INSTALLATION

- Check CVT fluid level and leakage. Refer to [TM-82, "Adjustment"](#).
- Check wheel alignment. Refer to [FSU-7, "Inspection"](#).
- Adjust the neutral position of the steering angle sensor. Refer to [BRC-248, "Description"](#).

A
B
C

FAX

E
F
G
H
I
J
K
L
M
N
O
P

FRONT DRIVE SHAFT

< UNIT DISASSEMBLY AND ASSEMBLY >

UNIT DISASSEMBLY AND ASSEMBLY

FRONT DRIVE SHAFT

Exploded View (LH)

INFOID:000000012203377

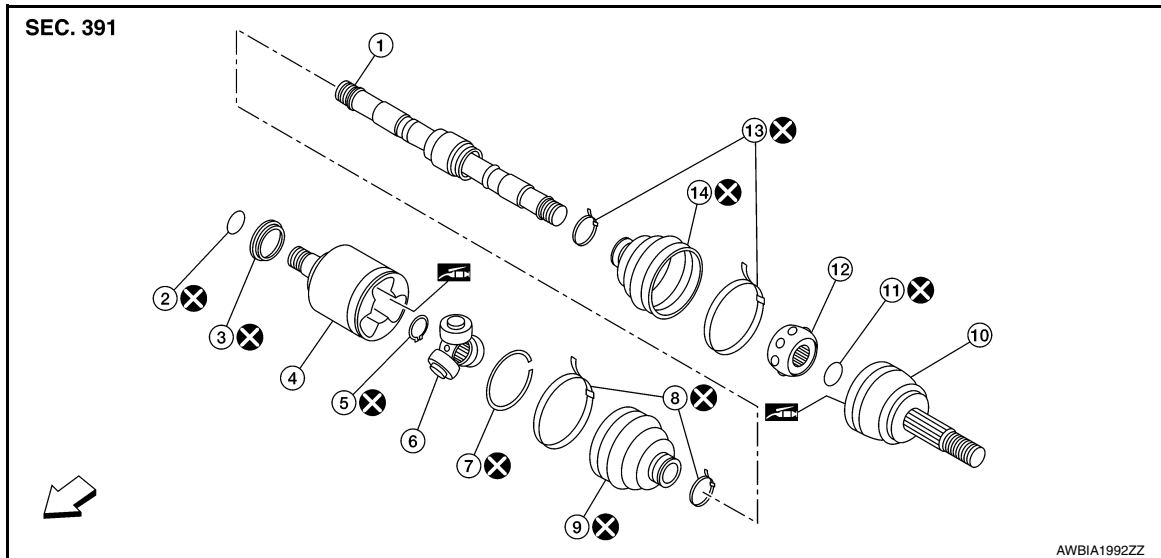

- | | | |
|------------------------|-------------------|--|
| 1. Shaft | 2. Circular clip | 3. Dust shield |
| 4. Housing | 5. Snap ring | 6. Spider assembly |
| 7. Stopper ring | 8. Boot band | 9. Boot |
| 10. Joint sub-assembly | 11. Circular clip | 12. Ball cage / Steel ball / Inner race assembly |
| 13. Boot band | 14. Boot | ← Front |

 Fill with Genuine NISSAN Grease.

Disassembly and Assembly (LH)

INFOID:000000011935314

DISASSEMBLY

Transaxle Side

1. Secure front drive shaft in a vise.

CAUTION:

When securing shaft in a vise, always use copper or aluminum plates between vise and shaft.

2. Remove boot bands and slide the boot back.
3. Remove circular clip and dust shield from housing.
4. Put matching marks on housing and shaft before separating joint assembly.

CAUTION:

Use paint or an equivalent for matching marks. Do not scratch surfaces.

5. Remove stopper ring with a suitable tool, then pull out housing.

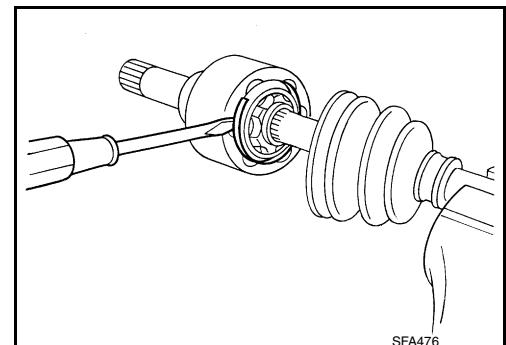

FRONT DRIVE SHAFT

< UNIT DISASSEMBLY AND ASSEMBLY >

- Put matching marks (A) on spider assembly and shaft.

CAUTION:

Use paint or an equivalent for matching marks. Do not scratch surfaces.

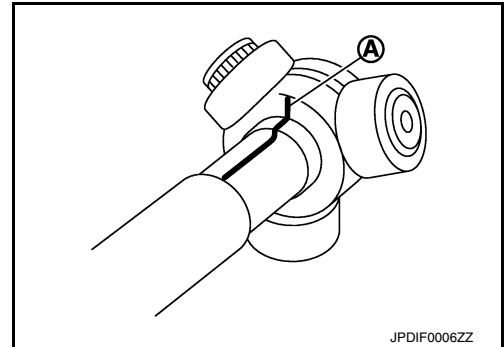

- Remove snap ring (1) using a suitable tool, then remove spider assembly from shaft.

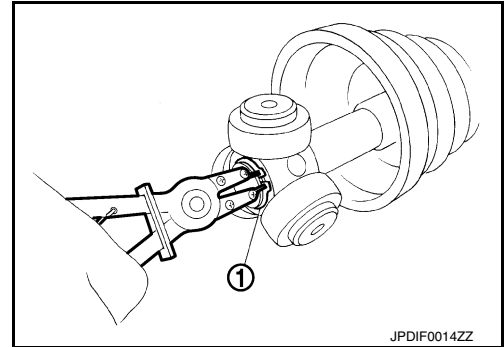

- Remove boot from shaft.
- Clean the old grease off the slide joint housing.

Wheel Side

- Secure the front drive shaft in a vise.

CAUTION:

When securing shaft in a vise, always use copper or aluminum plates between vise and shaft.

- Remove boot bands and slide the boot back.
- Screw a suitable tool (A) 30 mm (1.18 in) or more into threaded part of joint sub-assembly. Pull joint sub-assembly out of shaft.

CAUTION:

- Align suitable tool (B) and drive shaft then remove joint sub-assembly by pulling directly.
- If joint sub-assembly cannot be removed after five or more unsuccessful attempts, replace the entire drive shaft.

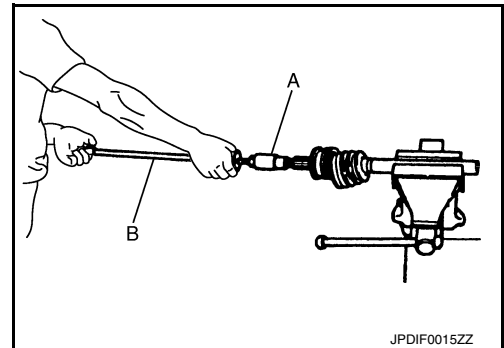

- Remove boot from shaft.
- Remove circular clip from shaft.
- While rotating ball cage, clean the old grease off the joint sub-assembly.

INSPECTION AFTER DISASSEMBLY

Shaft

- Check shaft for runout, cracks, or other damage. Replace entire drive shaft if necessary.

Joint Sub-Assembly

- Make sure there is no rough rotation or unusual axial looseness.
- Make sure there is no foreign material inside joint sub-assembly.
- Check joint sub-assembly for compression scars, cracks or fractures.

CAUTION:

If there are any irregular conditions of joint sub-assembly components, replace the entire joint sub-assembly.

A
B
C
FAX
E
F
G
H
I
J
K
L
M
N
O
P

FRONT DRIVE SHAFT

< UNIT DISASSEMBLY AND ASSEMBLY >

Housing

- Make sure there are no compression scars, cracks or fractures or unusual wear of ball rolling surface.
- Make sure there is no damage to shaft screws.
- Make sure there is no deformation of boot installation parts.

Ball Cage

- Make sure there are no compression scars, cracks, or fractures of sliding surface.

Steel Ball

- Make sure there are no compression scars, cracks, fractures or unusual wear.

Inner Race

- Check ball sliding surface for compression scars, cracks or fractures.
- Make sure there is no damage to serrated part.

CAUTION:

If there are any irregular conditions in the component, replace entire front drive shaft.

ASSEMBLY

Transaxle Side

1. Install new boot and new small boot band on shaft.

CAUTION:

- **Do not reuse the boot and boot bands.**
- **Cover drive shaft serration with protective tape (A) to prevent damage to boot during installation.**

2. Remove protective tape wound around serrated part of shaft.

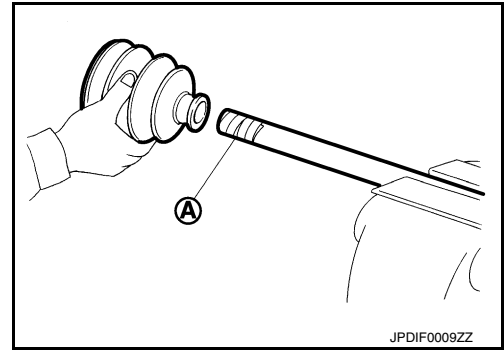

3. Align matching mark (A) on spider assembly (1) with matching mark on shaft (2). Install spider assembly to shaft with chamfer (B) facing shaft.

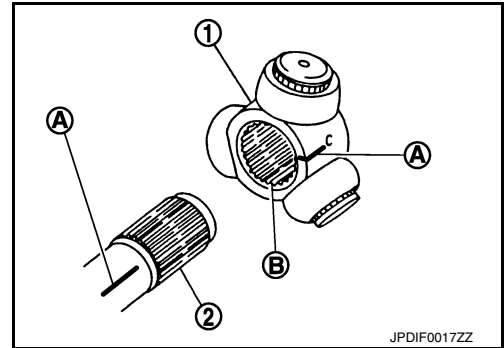

4. Install new snap ring (1) using a suitable tool.

CAUTION:

Do not reuse snap ring.

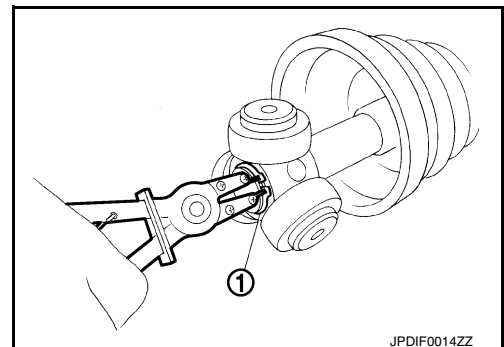

5. Assemble housing onto spider assembly making sure to align matching marks made during disassembly, and fill with specified amount of new Genuine NISSAN Grease.

Grease quantity : Refer to [FAX-37, "Drive Shaft"](#).

NOTE:

FRONT DRIVE SHAFT

< UNIT DISASSEMBLY AND ASSEMBLY >

Always check with the Parts Department for the latest parts information.

6. Install new stopper ring to housing.

CAUTION:

Do not reuse stopper ring.

7. After installation, pull shaft to check engagement between slide joint assembly and stopper ring.

8. Install boot securely into grooves (indicated by * marks) as shown.

CAUTION:

If there is grease on boot mounting surfaces (indicated by * marks) on shaft and housing, boot may come off. Clean all grease from surfaces.

9. Make sure boot installation length (L) is the length specified below. Insert a suitable tool into the large end of boot. Bleed air from boot to prevent boot deformation.

Boot installation length (L) : Refer to [FAX-37, "Drive Shaft"](#).

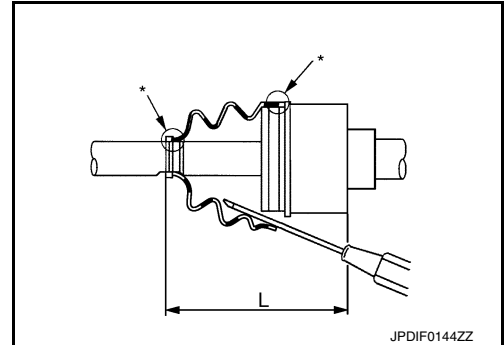

CAUTION:

- Boot may break if boot installation length is less than standard value.
- Be careful that suitable tool does not contact inside surface of boot.

10. Install new boot bands securely.

CAUTION:

Do not reuse boot band.

- a. Put boot band in the groove on drive shaft boot. Then fit pawls (←) into holes for temporary installation.

NOTE:

For the large diameter side, fit projection (A) and guide slit (B) at first.

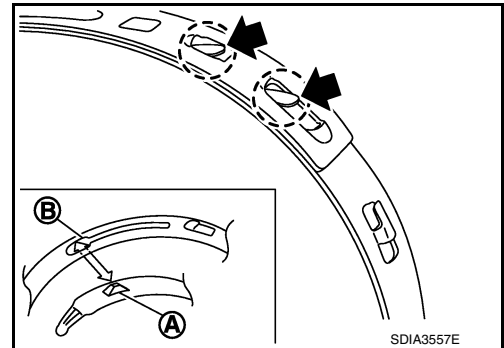

- b. Pinch projection on the band with suitable pliers to tighten band.

- c. Insert tip of band below end of the pawl.

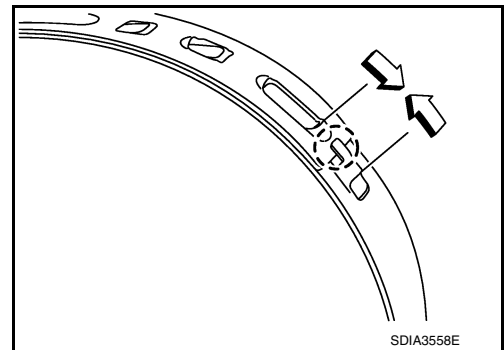

11. Install new dust shield to slide joint housing.

CAUTION:

Do not reuse dust shield.

12. Install new circular clip to housing.

CAUTION:

Do not reuse circular clip.

13. After installing housing and shaft, make sure boot position is correct. If boot position is not correct, remove old boot bands then reposition the boot and secure with new boot bands.

CAUTION:

A
B
C
FAX
E
F
G
H
I
J
K
L
M
N
O
P

FRONT DRIVE SHAFT

< UNIT DISASSEMBLY AND ASSEMBLY >

Do not reuse boot bands.

Wheel Side

1. Insert Genuine NISSAN Grease into joint sub-assembly (1) serration hole until grease begins to ooze from ball groove and serration hole.

CAUTION:

After inserting grease, use a paper shop cloth to wipe off old grease that has oozed out.

NOTE:

Always check with the Parts Department for the latest parts information.

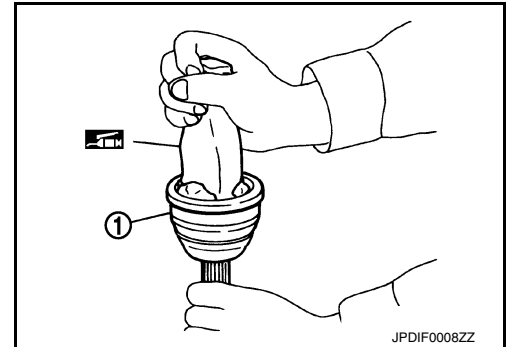

2. Install new boot and new small boot band on shaft.

CAUTION:

- Do not reuse the boot and boot bands.
- Cover drive shaft serration with protective tape (A) to prevent damage to boot during installation.

3. Remove protective tape wound around serrated part of shaft.

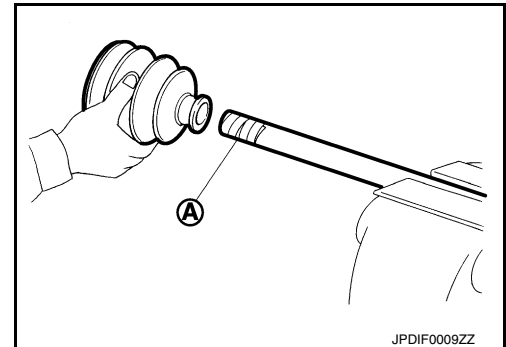

4. Attach new circular clip to shaft. Circular clip must fit securely into shaft groove. Attach nut to joint sub-assembly. Use a suitable tool to press-fit.

CAUTION:

Do not reuse circular clip.

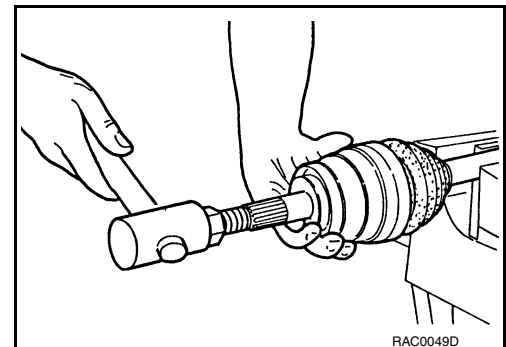

5. Insert specified amount of new Genuine NISSAN Grease listed below into housing from large end of boot.

Grease quantity : Refer to [FAX-37, "Drive Shaft"](#).

NOTE:

Always check with the Parts Department for the latest parts information.

6. Install boot securely into grooves (indicated by * marks) as shown.

CAUTION:

If there is grease on boot mounting surfaces (indicated by * marks) on shaft and housing, boot may come off. Remove all grease from surfaces.

7. Make sure boot installation length (L) is the specified length indicated below. Insert a suitable tool into the large end of boot. Bleed air from boot to prevent boot deformation.

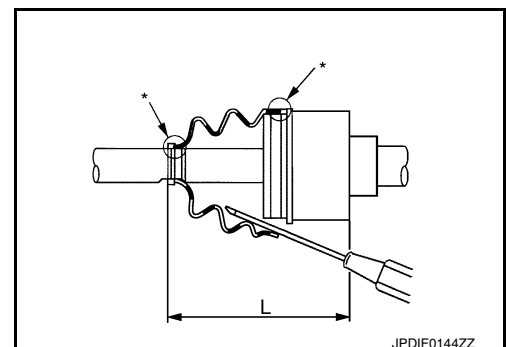

Boot installation length (L) : Refer to [FAX-37, "Drive Shaft"](#).

CAUTION:

- Boot may break if boot installation length is less than standard value.

FRONT DRIVE SHAFT

< UNIT DISASSEMBLY AND ASSEMBLY >

- Be careful that suitable tool does not contact inside surface of boot.

8. Install new large and small boot bands securely using Tool.

Tool number : KV40107300 (J-51751)

CAUTION:

Do not reuse boot bands.

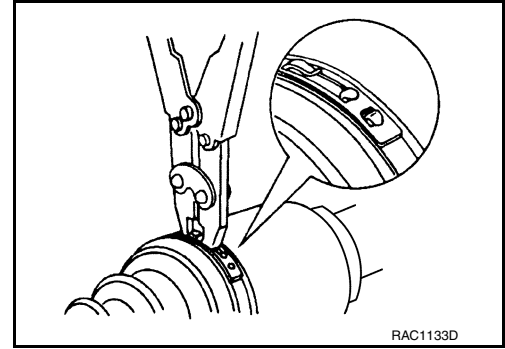

RAC1133D

NOTE:

Secure boot band so that dimension (M) meets specification as shown.

Dimension (M) : Refer to FAX-38, "Boot Bands".

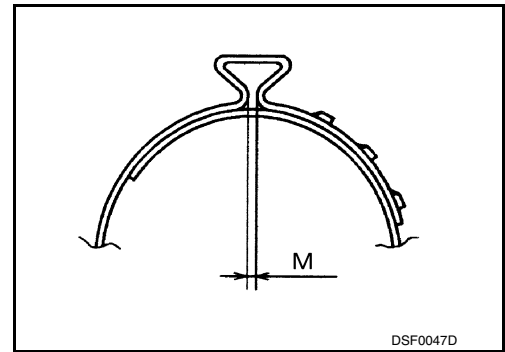

DSF0047D

9. Attempt to rotate boot to check whether or not boot bands are securing it. If boot is not secure, remove boot bands, reposition boot, and install new boot bands.

CAUTION:

Do not reuse boot bands.

Exploded View (RH)

INFOID:000000012203378

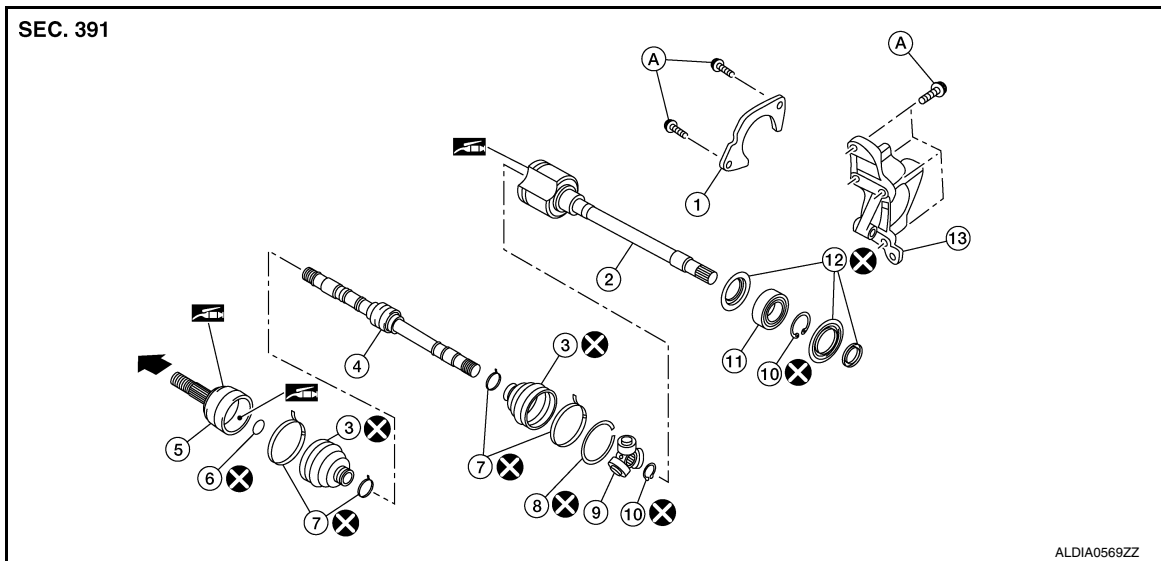

- | | | |
|-----------------------------|-----------------------|--------------------|
| 1. Support bearing retainer | 2. Housing | 3. Boot |
| 4. Shaft with damper | 5. Joint sub-assembly | 6. Circular clip |
| 7. Boot band | 8. Stopper ring | 9. Spider assembly |
| 10. Snap ring | 11. Support bearing | 12. Dust shield |

FRONT DRIVE SHAFT

< UNIT DISASSEMBLY AND ASSEMBLY >

13. Support bearing bracket

A. Refer to FRONT DRIVE SHAFT INSTALLATION. ← Wheel side

 Fill with Genuine NISSAN Grease.

Disassembly and Assembly (RH)

INFOID:000000011935315

DISASSEMBLY

Transaxle Side

1. Secure shaft in a vise.

CAUTION:

When securing shaft in a vise, always use copper or aluminum plates between vise and shaft.

2. Remove circular clip and dust shield from housing.

3. Remove boot bands and slide the boots back.

4. Put matching marks on housing and shaft before separating housing.

CAUTION:

Use paint or an equivalent for matching marks. Do not scratch surfaces.

5. Remove stopper ring using a suitable tool, then pull out housing.

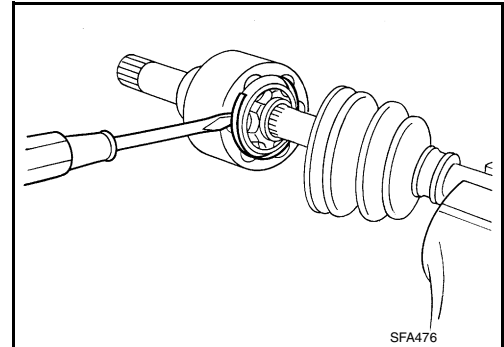

6. Put matching marks (A) on spider assembly and shaft.

CAUTION:

Use paint or an equivalent for matching marks. Do not scratch surfaces.

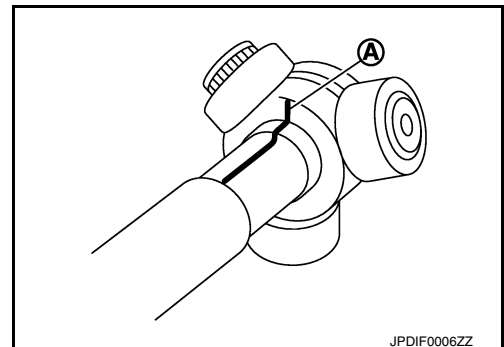

7. Remove snap ring (1) using a suitable tool, then remove spider assembly from shaft.

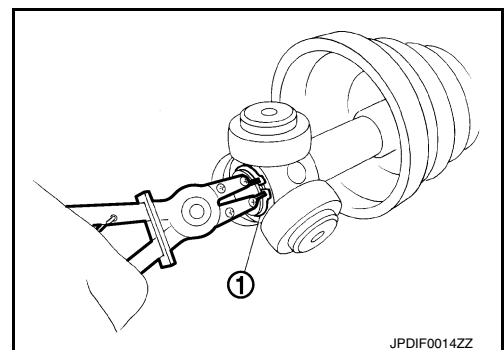

8. Remove boot from shaft.

9. Remove dust shield from housing.

10. Clean old grease off housing.

FRONT DRIVE SHAFT

< UNIT DISASSEMBLY AND ASSEMBLY >

Support Bearing

1. Remove dust shield from housing using a suitable tool.

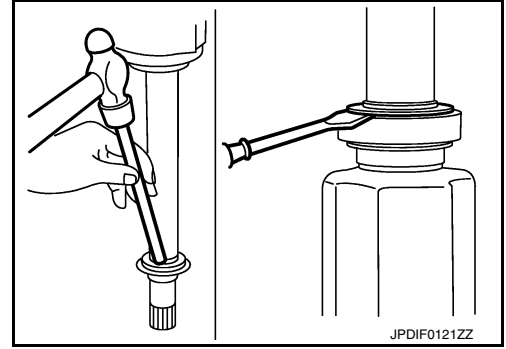

A
B
C

FAX

2. Remove snap ring (1) using a suitable tool.

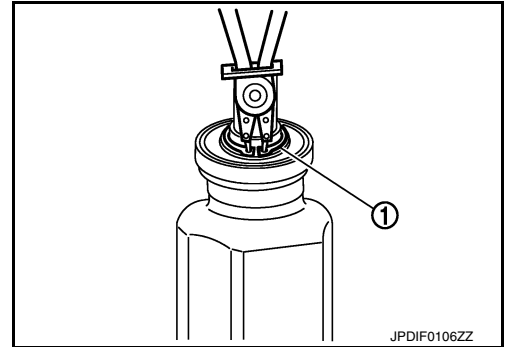

E
F
G

3. Press support bearing off housing using a suitable tool.

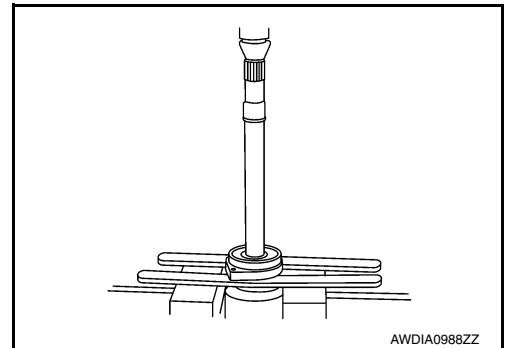

H
I
J

4. Remove dust shield.

Wheel Side

1. Secure the front drive shaft in a vise.

CAUTION:

When securing shaft in a vise, always use copper or aluminum plates between vise and shaft.

2. Remove boot bands and slide the boot back.
3. Screw a suitable tool (A) 30 mm (1.18 in) or more into threaded part of joint sub-assembly. Pull joint sub-assembly out of shaft.

CAUTION:

- **Align suitable tool (B) and drive shaft then remove joint sub-assembly by pulling directly.**
- **If joint sub-assembly cannot be removed after five or more unsuccessful attempts, replace the entire drive shaft.**

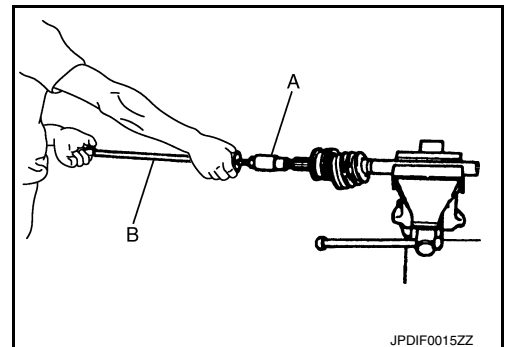

L
M
N
O
P

4. Remove boot from shaft.
5. Remove circular clip from shaft.

FRONT DRIVE SHAFT

< UNIT DISASSEMBLY AND ASSEMBLY >

6. While rotating ball cage, clean the old grease off the joint sub-assembly.

INSPECTION AFTER DISASSEMBLY

Shaft

• Check shaft for runout, cracks, or other damage. Replace entire drive shaft if necessary.

Joint Sub-assembly

- Make sure there is no rough rotation or unusual axial looseness.
- Make sure there is no foreign material inside joint sub-assembly.
- Check joint sub-assembly for compression scars, cracks or fractures.

CAUTION:

If there are any irregular conditions of joint sub-assembly components, replace the entire drive shaft.

Sliding Joint Housing and Spider Assembly

• If roller surface of spider assembly has scratches or wear, replace housing and spider assembly.

NOTE:

Housing and spider assembly are components which are used as a set.

Support Bearing

• Make sure support bearing rolls freely and is free from noise, cracks, pitting or wear.

ASSEMBLY

Transaxle Side

1. Install new boot and new small boot band onto shaft. Be careful not to damage boot.

CAUTION:

- Do not reuse boot and boot bands.
- Cover drive shaft serration with protective tape (A) to prevent damage to boot during installation.

2. Remove protective tape wound around serrated part of shaft.

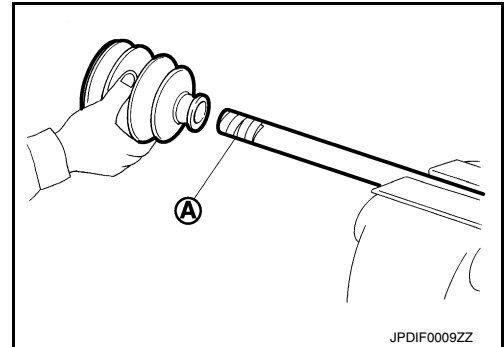

3. Align matching mark (A) on spider assembly (1) with matching mark on shaft (2). Install spider assembly to shaft with chamfer (B) facing shaft.

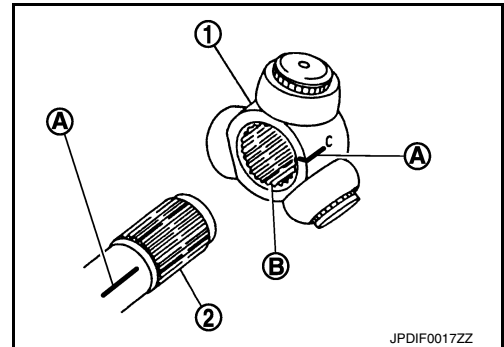

4. Install new snap ring (1) using a suitable tool.

CAUTION:

Do not reuse snap ring.

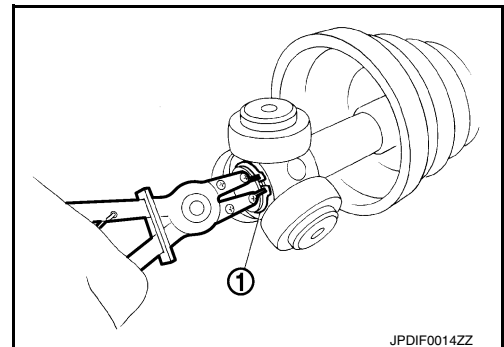

FRONT DRIVE SHAFT

< UNIT DISASSEMBLY AND ASSEMBLY >

5. Assemble housing onto spider assembly making sure to align matching marks made during disassembly, and fill with specified amount of Genuine NISSAN Grease.

Grease quantity : Refer to [FAX-37, "Drive Shaft"](#).

NOTE:

Always check with the Parts Department for the latest parts information.

6. Install new stopper ring to housing.

CAUTION:

Do not reuse stopper ring.

7. After installation, pull shaft to check engagement between housing and stopper ring.

8. Install boot securely into grooves (indicated by * marks) as shown.

CAUTION:

If there is grease on boot mounting surfaces (indicated by * marks) on shaft and housing, boot may come off. Remove all grease from surfaces.

9. Make sure boot installation length (L) is the length indicated below. Insert a suitable tool into the large end of boot. Bleed air from boot to prevent boot deformation.

Boot installation length (L) : Refer to [FAX-37, "Drive Shaft"](#).

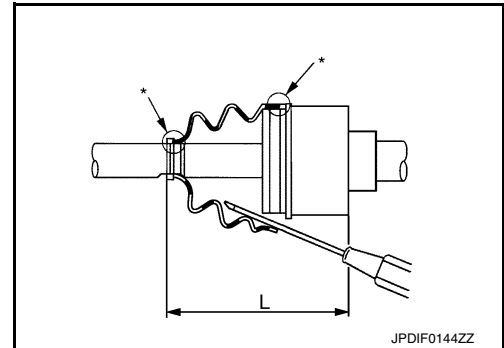

CAUTION:

- **Boot may break if boot installation length is less than standard value.**
- **Be careful that suitable tool does not contact inside surface of boot.**

10. Install new boot bands securely.

CAUTION:

Do not reuse boot band.

- a. Put boot band in the groove on drive shaft boot. Then fit pawls (←) into holes for temporary installation.

NOTE:

For the large diameter side, fit projection (A) and guide slit (B) at first.

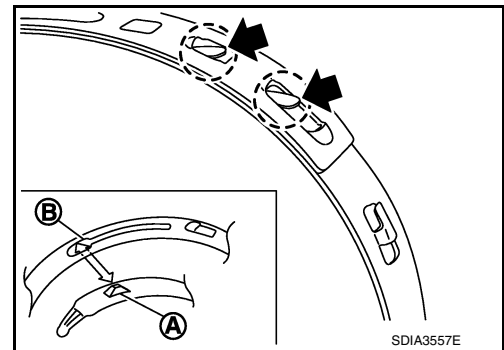

- b. Pinch projection on the band with suitable pliers to tighten band.

- c. Insert tip of band below end of the pawl.

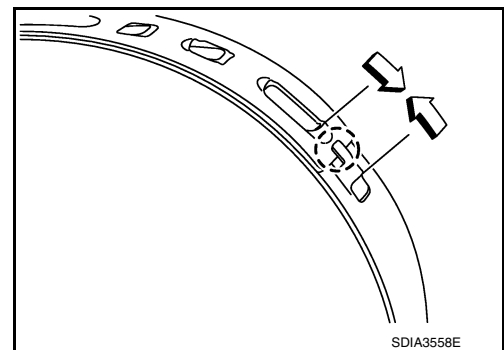

11. Install new dust shield to housing.

CAUTION:

Do not reuse dust shield.

12. Install new circular clip to housing.

CAUTION:

A
B
C
FAX
E
F
G
H
I
J
K
L
M
N
O
P

FRONT DRIVE SHAFT

< UNIT DISASSEMBLY AND ASSEMBLY >

Do not reuse circular clip.

13. After installing housing and shaft, rotate boot to check whether or not the actual position is correct. If boot position is not correct, remove old boot bands then reposition the boot and secure with new boot bands.

CAUTION:

Do not reuse boot bands.

Wheel Side

1. Insert Genuine NISSAN Grease into joint sub-assembly (1) serration hole until grease begins to ooze from ball groove and serration hole.

CAUTION:

After inserting grease, use a paper shop cloth to wipe off old grease that has oozed out.

NOTE:

Always check with the Parts Department for the latest parts information.

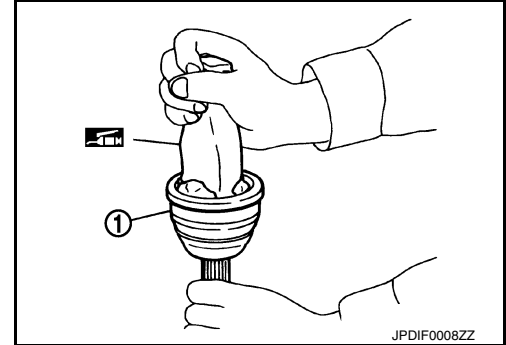

2. Install new boot and new small boot band onto shaft. Be careful not to damage boot.

CAUTION:

- Do not reuse boot and boot bands.
- Cover drive shaft serration with protective tape (A) to prevent damage to boot during installation.

3. Remove protective tape wound around serrated part of shaft.

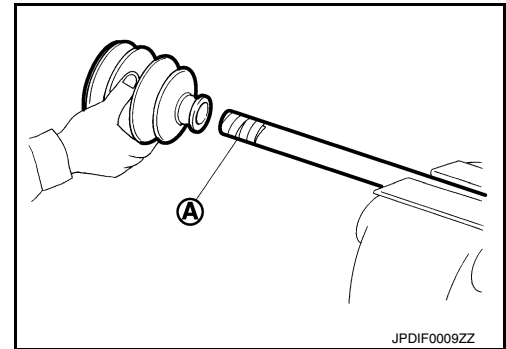

4. Attach new circular clip to shaft. Circular clip must fit securely into shaft groove. Attach nut to joint sub-assembly. Use a suitable tool to press-fit.

CAUTION:

Do not reuse circular clip.

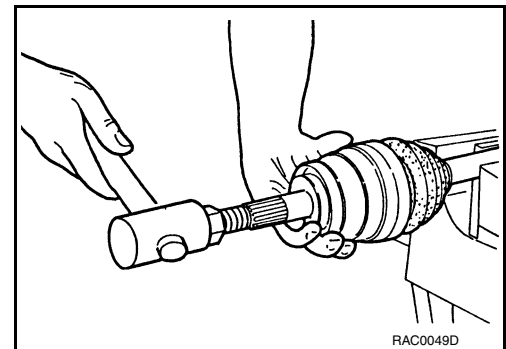

5. Insert the amount of new Genuine NISSAN Grease listed below into housing from large end of boot.

Grease quantity : Refer to [FAX-37, "Drive Shaft"](#).

6. Install boot securely into grooves (indicated by * marks) as shown.

CAUTION:

If there is grease on boot mounting surfaces (indicated by * marks) of shaft and housing, boot may come off. Remove all grease from surfaces.

7. Make sure boot installation length (L) is the specified length. Insert a suitable tool into the large end of boot. Bleed air from boot to prevent boot deformation.

Boot installation length (L) : Refer to [FAX-37, "Drive Shaft"](#).

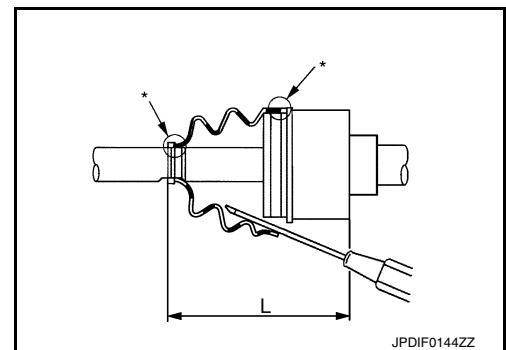

FRONT DRIVE SHAFT

< UNIT DISASSEMBLY AND ASSEMBLY >

CAUTION:

- Boot may break if boot installation length is less than standard value.
- Be careful that suitable tool does not contact inside surface of boot.

8. Install new large and small boot bands securely using Tool.

Tool number : KV40107300 (J-51751)

CAUTION:

Do not reuse boot bands.

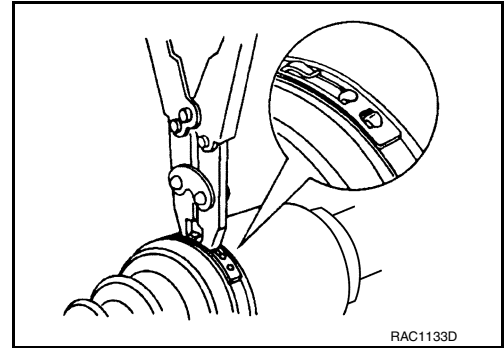

NOTE:

Secure boot band so that dimension (M) meets specification as shown.

Dimension (M) : Refer to [FAX-38, "Boot Bands"](#).

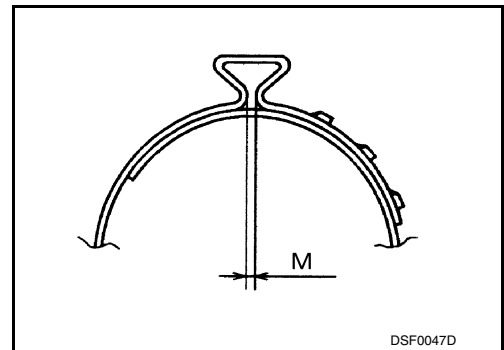

9. Attempt to rotate boot to check whether or not boot bands are securing it. If boot is not secure, remove boot bands, reposition boot, and install new boot bands.

CAUTION:

Do not reuse boot bands.

Support Bearing

1. Install dust shield on housing.

CAUTION:

Do not reuse dust shield.

2. Press support bearing (1) onto housing using a suitable tool (A).

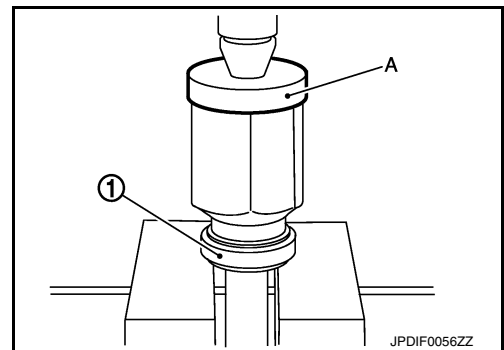

A
B
C
FAX
E
F
G
H
I
J
K
L
M
N
O
P

FRONT DRIVE SHAFT

< UNIT DISASSEMBLY AND ASSEMBLY >

3. Install snap ring (1) using a suitable tool.

CAUTION:

Do not reuse snap ring.

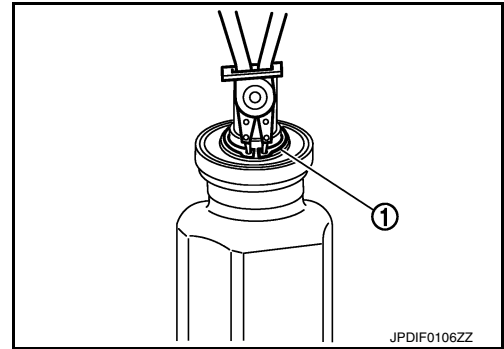

4. Install dust shields.

CAUTION:

Do not reuse dust shields.

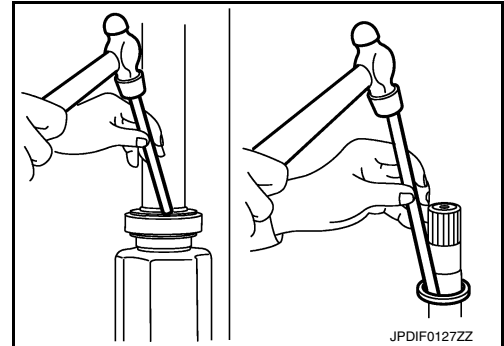

SERVICE DATA AND SPECIFICATIONS (SDS)

< SERVICE DATA AND SPECIFICATIONS (SDS)

SERVICE DATA AND SPECIFICATIONS (SDS)

SERVICE DATA AND SPECIFICATIONS (SDS)

Wheel Bearing

INFOID:0000000011935316

Axial end play limit	0.05 mm (0.002 in) or less
----------------------	----------------------------

Drive Shaft

INFOID:0000000011935317

FAX

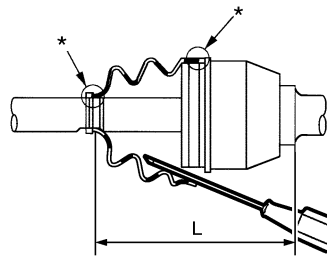

JPDIF0142ZZ

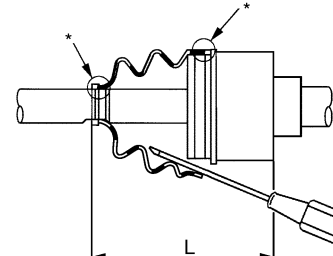

JPDIF0144ZZ

Joint type	Wheel side		Transaxle side	
	LH	RH	LH	RH
Grease quantity	115 ± 5 g (4.06 ± 0.18 oz)		139 ± 5 g (4.90 ± 0.18 oz)	
Boot installation length (L)	146.7 mm (5.78 in)		166.7 mm (6.56 in)	

*: Boot installation grooves

Dynamic Damper

INFOID:0000000011935318

NOTE:

Measured from wheel side.

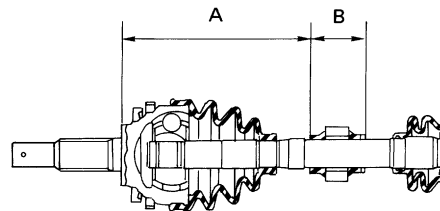

SFA313B

	LH	RH
Dimension (A)	220 ± 3 mm (8.66 ± 0.12 in)	205 ± 3 mm (8.07 ± 0.12 in)
Dimension (B)	50 mm (2.76 in)	50 mm (2.76 in)

SERVICE DATA AND SPECIFICATIONS (SDS)

< SERVICE DATA AND SPECIFICATIONS (SDS)

Boot Bands

INFOID:000000011935319

Unit: mm (in)

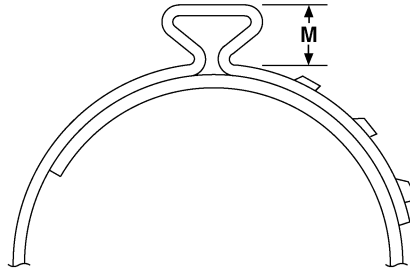

AWDIA0598ZZ

Dimension (M)	7.0 (0.28)
---------------	------------